

SMA SUNNY ISLAND-SUPPORTED BATTERY MANAGEMENT SYSTEM WITH CHARGER ENABLE REC 1Q-16S



Features:

- robust and small design
- 5 – 16 cells
- single cell voltage measurement (0.1 – 5.0 V, resolution 1 mV)
- single cell - under/over voltage protection
- single cell internal resistance measurement
- SOC and SOH calculation
- over/under temperature protection (up to 4 temperature sensors)
- passive cell balancing 4.3 Ω
- 18-bit shunt current measurement (resolution 7.8 mA @ ± 200 A)
- galvanically isolated user defined multi-purpose digital output
- programmable relay (normally open)
- galvanically isolated RS-485 communication protocol
- CAN communication
- error LED + buzzer indicator
- PC user interface for changing settings, data-logging and firmware update (optional accessory)
- hibernate switch
- one-year warranty
- **NEW:** reduced 1 s measuring interval
- **NEW:** balancing transistors defect check @ restart
- **NEW:** EEPROM memory data corruption check @ restart
- **NEW:** cell's voltage RMS voltage measurement
- **NEW:** self calibration @ restart

- **NEW:** BMS shutdown @ 0.98 x minimum cell disconnect threshold
- **NEW:** Ah counting

General description of the BMS Unit:

Battery management system (BMS) is a device that monitors and controls each cell in the battery pack by measuring its parameters. The capacity of the battery pack differs from one cell to another and this increases with number of charging/discharging cycles. The Li-poly batteries are fully charged at typical cell voltage 4.16 - 4.20 V or 3.5 – 3.6 V for LiFePO₄. Due to the different capacity this voltage is not reached at the same time for all cells in the pack. The lower the cell's capacity the sooner this voltage is reached. When charging series connected cells with a single charger, voltage on some cells might be higher than maximum allowed voltage. Overcharging the cell additionally lowers its capacity and number of charging cycles. The BMS equalizes cells' voltage by diverting some of the charging current from higher voltage cells – passive balancing. The device temperature is measured to protect the circuit from over-heating due to the passive balancing. Battery pack temperature is monitored by Dallas DS18B20 digital temperature sensor/s. Maximum 4 temperature sensors per unit may be used. Current is measured by low-side shunt resistor. Battery pack current, temperature and cell's voltage determine state of charge (SOC). State of health (SOH) is determined by comparing cell's current parameters with the parameters of the new battery pack. The BMS default parameters are listed in Table 1.

Default Parameters:

Table 1: Default BMS parameter settings.

PARAMETER	VALUE	UNIT
chemistry	3(LiFePO ₄)	n.a.
capacity	500	Ah
balance start voltage	3.45	V
balance end voltage	3.58	V
maximum diverted current per cell	up to 0.85 (4.3 Ohm)	A
cell over voltage switch-off	3.85	V
cell over voltage switch-off hysteresis per cell	0.1	V
charger end of charge switch-off pack	3.58	V
charger end of charge switch-off hysteresis	0.25	V
cell under voltage protection switch-off	2.8	V
cell under voltage discharge protection	2.9	V
under voltage protection switch-off hysteresis per cell	0.05	V
BMS under voltage protection switch-off timer	20	s
BMS switch-off under voltage protection per cell	2.8x0.98	V
cells max difference	0.25	V
BMS maximum pack voltage	68.0	V
BMS charge/discharge SOC hysteresis	5	%
BMS over temperature switch-off	55	°C
BMS over temperature switch-off hysteresis	5	°C
cell over temperature switch-off	55	°C
under temperature charging disable	-15	°C
voltage to current coefficient	0.0078125	A/bit
maximum charging/discharging current per SI device	90/100	A
Number of SI devices	1	n.a.
max DC current relay @ 60 V DC	0.7	A
max AC current relay @ 230 V AC	2	A
BMS unit stand-by power supply	< 90	mW
max DC current @ optocoupler	<10	mA
max DC voltage@ optocoupler	62.5	V
BMS unit disable power supply	< 1	mW
BMS unit cell balance fuse rating (SMD)	2	A
internal relay fuse	2 slow	A
dimensions (w × l × h)	190 x 104 x 39	mm
IP protection	IP32	

System overview:

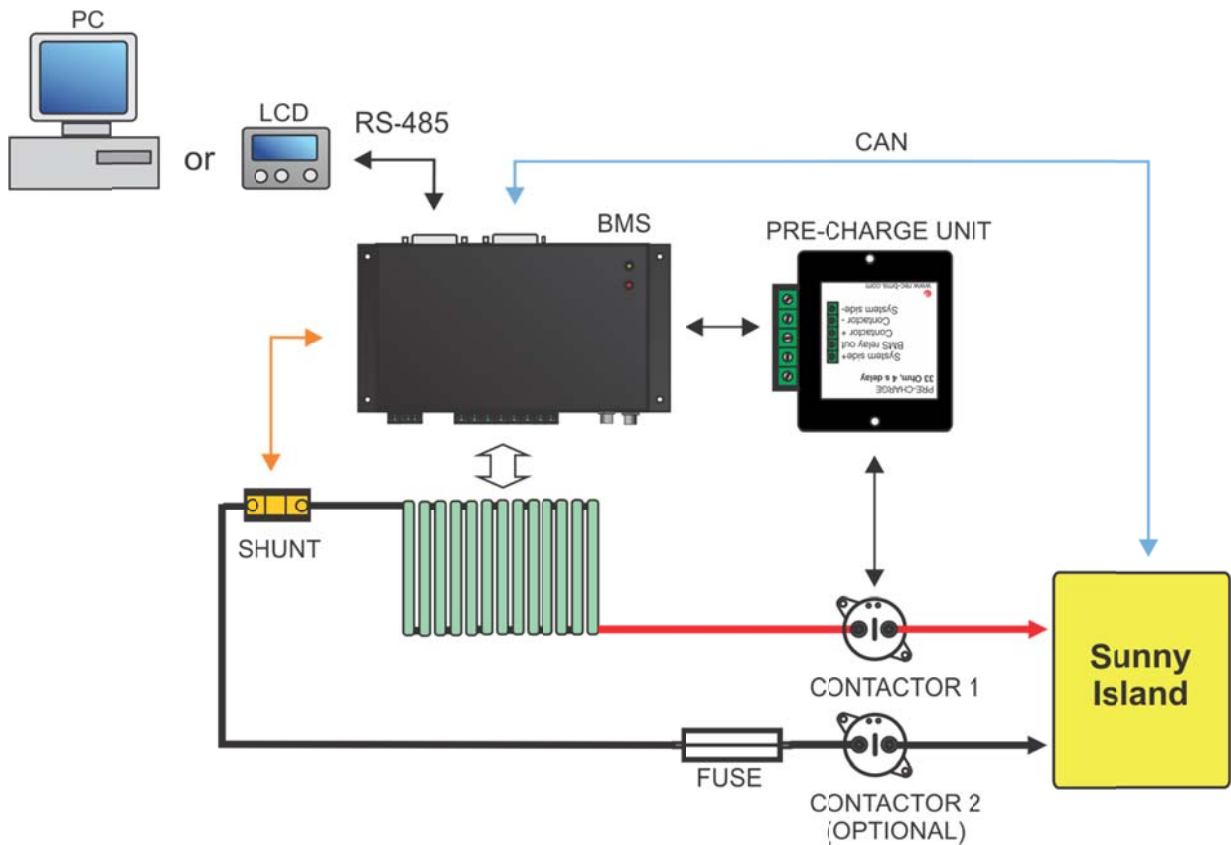

Figure 1: System overview.

BMS Unit connections:

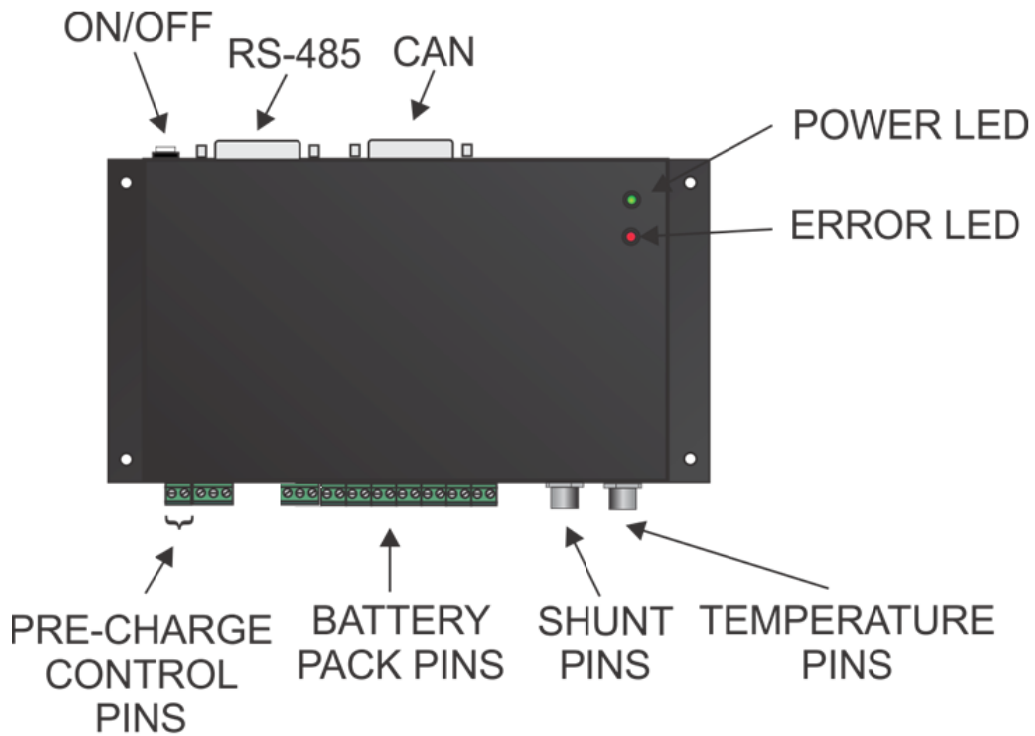

Figure 2: BMS unit function overview.

Table 2: BMS unit connections.

CONNECTION	DESCRIPTION	
Temperature sensor connector pins	DALLAS DS18B20 temp. sensor pins (pin 2)	GND + shield
	DALLAS DS 18B20 temp. sensor pins (pin 3)	1-wire digital signal
	DALLAS DS18B20 temp. sensor pins (pin 1)	+ 5 V
Current sensor Connector pins	+ Shunt (pin 1)	Analog signal
	- Shunt (pin 3)	Analog signal
	Shield (pin 2)	Analog signal
Cells connector pins		
1	Cell 1 ground	Analog signal
2	Cell 1 positive	Analog signal
3	Cell 2 positive	Analog signal
4	Cell 3 positive	Analog signal
5	Cell 4 positive	Analog signal
6	Cell 5 positive	Analog signal
7	Cell 6 positive	Analog signal
8	Cell 7 positive	Analog signal
9	Cell 8 positive	Analog signal
10	Cell 9 positive	Analog signal
11	Cell 10 positive	Analog signal
12	Cell 11 positive	Analog signal
13	Cell 12 positive	Analog signal
14	Cell 13 positive	Analog signal
15	Cell 14 positive	Analog signal
16	Cell 15 positive	Analog signal
17	Cell 16 positive	Analog signal
I/O pins		
1	Charger ENABLE open collector	-
2	Charger ENABLE open emitter	-
3	-	-
4	Internal Relay – pre-charge control	-
5	Internal Relay – pre-charge control	-

Setting number of cells and the RS-485 address:

Number of cells connected to the BMS unit is selected via CELL DIP Switch pins at the back of the unit. Binary addressing is used to enable setting up to 16 cells with 4 DIP Switches.

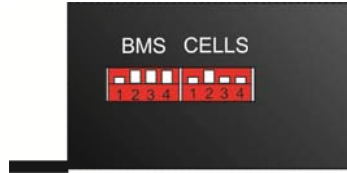

Figure 3: Address and cell selection DIP Switches.

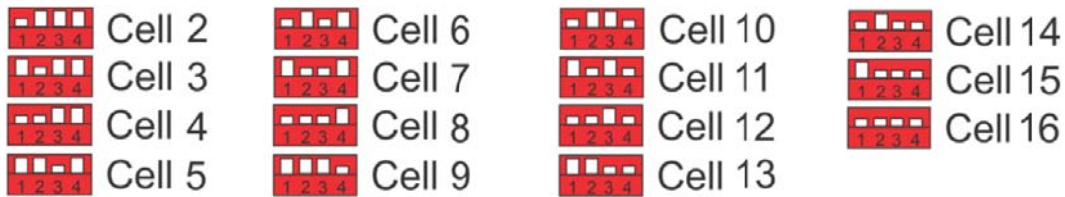

Figure 4: Number of cell selection description.

BMS unit address is selected via Address DIP Switch pins (BMS) at the back of the unit. Binary addressing is used to enable setting up to 15 addresses with 4 DIP Switches. **! If multiple BMS units are used distinguished addresses should be set to avoid data collision on the RS-485 communication bus!**

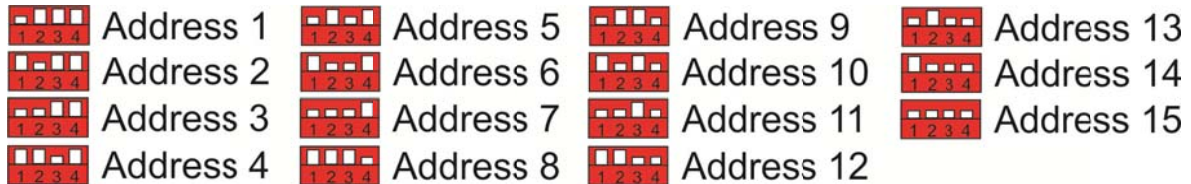

Figure 5: BMS unit address selection description.

BMS Unit cell connector:

Connect each cell to the BMS unit cell connector plug. Use silicon wires with cross section of 0.5 - 1 mm² (25-23 AWG). **! Before inserting the cell connector check voltages and polarities with voltmeter of each connection!**

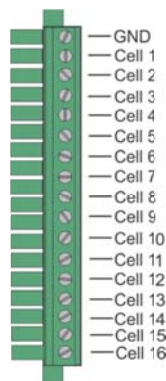

Figure 6: Battery pack to BMS connection.

BMS Unit power supply:

BMS unit is always supplied from the 16-th cell connection. **! When less than 16 cells are used in the battery pack, an additional wire with Pack + voltage should be connected to the cell 16 connector !**

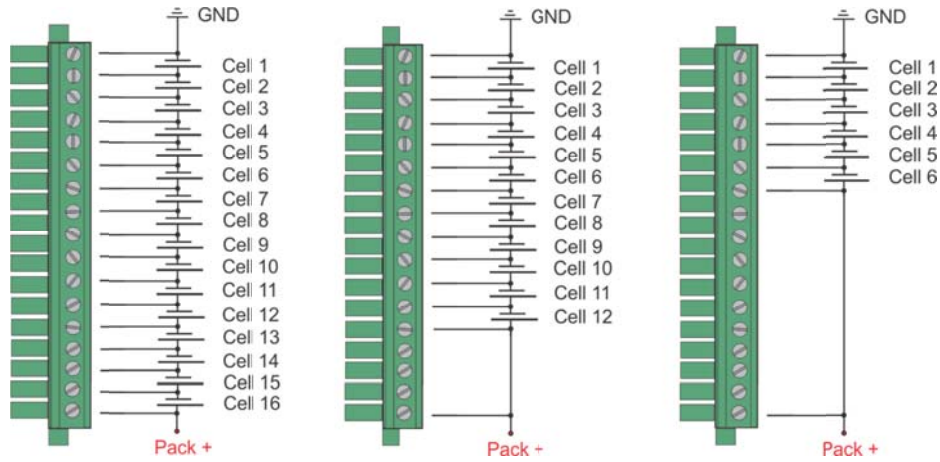

Figure 7: BMS unit power supply.

BMS Unit connection instructions:

Connect the BMS unit to the system by the following order described in Fig. 8. It is important to disable all the BMS functions by turning enable switch OFF before plugging any connectors. **All cells should be connected last and simultaneously.** When all the system components are plugged in, the enable switch can be turned ON and the BMS starts the test procedure.

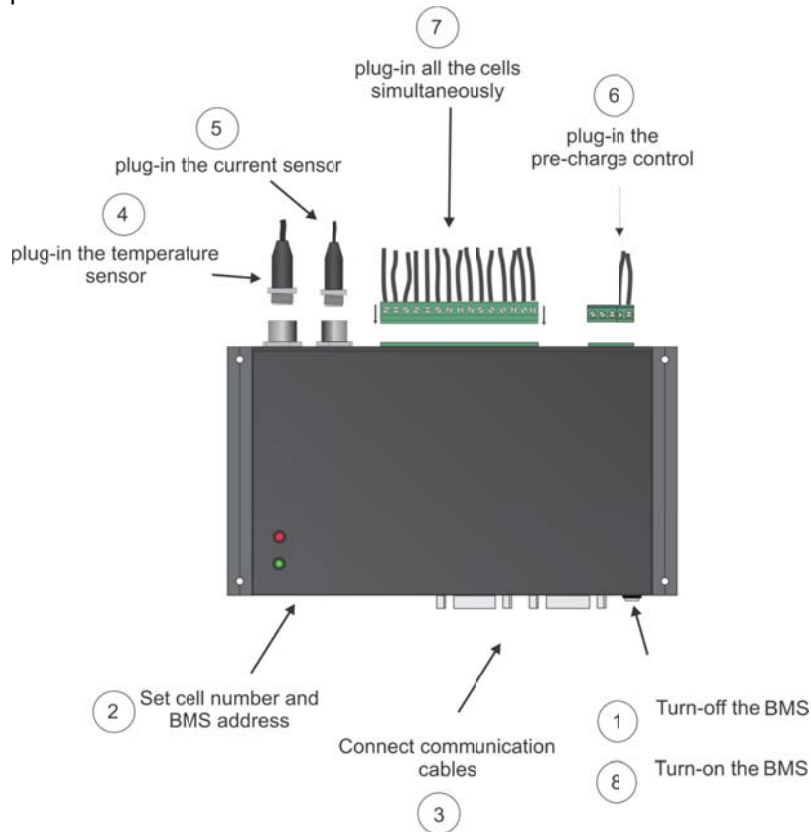

Figure 8: BMS connection order.

When disconnecting the unit from the battery pack, the procedure should be followed in reverse order.

RS-485 communication protocol:

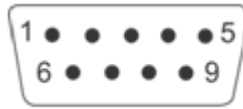

Figure 9: RS-485 DB9 connector front view.

Table 3: RS-485 DB9 connector pin designator.

Pin	Designator
1	-
2	GND
3	B
4	A
5	-
6	+5V
7	-
8	-
9	-

Galvanically isolated RS-485 (EN 61558-1, EN 61558-2) serves for logging and changing BMS parameters. Dedicated PC BMS Control Software or another RS-485 device may be used for the communication.

Messages are comprised as follows:

STX, DA, SA, N, INSTRUCTION- 4 bytes, 16-bit CRC, ETX

- STX start transmission <0x55> (always)
- DA - destination address <0x01> to <0x10> (set as 6)
- SA - sender address <0x00> (always 0)
- N – number of sent bytes
- INSTRUCTION 4 bytes for example.: 'L','C','D','1','?', - (combined from 4 ASCII characters, followed by '?', if we would like to receive the current parameter value or ',' , 'xx.xx' value in case we want to set a new value
- 16-bit CRC, for the whole message except STX in ETX
- ETX - end transmission <0xAA> (always)

Dataflow:

- Bit rate: 56k
- Data bits: 8
- Stop bits: 1
- Parity: None
- Mode: Asynchronous

Table 4: RS-485 instruction set.

INSTRUCTION	DESCRIPTION	BMS ANSWER
'*', 'I', 'D', 'N', '?'	Identification	Answer "REC - BATTERY MANAGEMENT SYSTEM"
'L', 'C', 'D', '1', '?'	Main data	Returns 7 float values LCD1 [0] = min cell voltage, LCD1 [1] = max cell voltage, LCD1 [2] = current, LCD1 [3] = max temperature, LCD1 [4] = pack voltage, LCD1 [5] = SOC (state of charge) interval 0-1-> 1=100% and LCD1 [6] = SOH (state of health) interval 0-1-> 1=100%
'L', 'C', 'D', '3', '?'	Main data	Returns 8 unsigned char values LCD3 [0] = min cell BMS address, LCD3 [1] = min cell number, LCD3 [2] = max cell BMS address, LCD3 [3] = max cell number, LCD3 [4] = max temp. sens. BMS address, LCD3 [5] = max temp. sens. number, LCD3 [6] = Ah MSB, LCD3 [7] = Ah LSB
'C', 'E', 'L', 'L', '?'	Cell voltages	BMS first responds with how many BMS units are connected, then it sends the values of the cells in float format
'P', 'T', 'E', 'M', '?'	Cell temperatures	BMS first responds with how many BMS units are connected then it sends the values of the temperature sensors in float format
'R', 'I', 'N', 'T', '?'	Cells internal DC resistance	BMS first responds with how many BMS units are connected then it sends the values in float format
'B', 'T', 'E', 'M', '?'	BMS temperature	BMS first responds with value 1, then it sends the values of the BMS temperature sensor in float format
'B', 'V', 'O', 'L', '?' / 'B', 'V', 'O', 'L', ' ', ' ', 'xxx'	Cell END balancing	Returns float voltage [V]
'C', 'M', 'A', 'X', '?' / 'C', 'M', 'A', 'X', ' ', ' ', 'xxx'	Max allowed cell voltage	Returns float voltage [V]
'M', 'A', 'X', 'H', '?' / 'M', 'A', 'X', 'H', ' ', ' ', 'xxx'	Max allowed cell voltage hysteresis	Returns float voltage [V]
'C', 'M', 'I', 'N', '?' / 'C', 'M', 'I', 'N', ' ', ' ', 'xxx'	Min allowed cell voltage	Returns float voltage [V]
'M', 'I', 'N', 'H', '?' / 'M', 'I', 'N', 'H', ' ', ' ', 'xxx'	Min allowed cell voltage hysteresis	Returns float voltage [V]
'T', 'M', 'A', 'X', '?' / 'T', 'M', 'A', 'X', ' ', ' ', 'xxx'	Maximum allowed cell temperature	Returns float temperature [°C]
'T', 'M', 'I', 'N', '?' / 'T', 'M', 'I', 'N', ' ', ' ', 'xxx'	Minimum allowed temperature for charging	Returns float temperature [°C]
'B', 'M', 'I', 'N', '?' / 'B', 'M', 'I', 'N', ' ', ' ', 'xxx'	Balancing START voltage	Returns float voltage [V]
'C', 'H', 'A', 'R', '?' / 'C', 'H', 'A', 'R', ' ', ' ', 'xxx'	End of charging voltage per cell	Returns float voltage [V]
'C', 'H', 'I', 'S', '?' / 'C', 'H', 'I', 'S', ' ', ' ', 'xxx'	End of charging voltage hysteresis per cell	Returns float voltage [V]
'I', 'O', 'F', 'F', '?' / 'I', 'O', 'F', 'F', ' ', ' ', 'xxx'	Current measurement zero offset	Returns float current [A]

BATTERY MANAGEMENT SYSTEM 1Q FOR SMA SI

'T','B','A','L','?'/ 'T','B','A','L',' ','xxx'	Max allowed BMS temperature	Returns float temperature [°C]
'B','M','T','H','?'/ 'B','M','T','H',' ','xxx'	Max allowed BMS temperature hysteresis	Returns float temperature [°C]
'V','M','A','X','?'/ 'V','M','A','X',' ','xxx'	Number of exceeded values of CMAX	Returns integer value
'V','M','I','N','?'/ 'V','M','I','N',' ','xxx'	Number of exceeded values of CMIN	Returns integer value
'T','H','I','S','?'/ 'T','H','I','S',' ','xxx'	Number of exceeded values of TMAX	Returns integer value
'C','Y','C','L','?'/ 'C','Y','C','L',' ','xxx'	Number of battery pack cycles	Returns integer value
'C','A','P','A','?'/ 'C','A','P','A',' ','xxx'	Battery pack capacity	Returns float capacity [Ah]
'I','O','J','A','?'/ 'I','O','J','A',' ','xxx'	Voltage to current coefficient	Returns float value
'R','A','Z','L','?'/ 'R','A','Z','L',' ','xxx'	Package cell difference	Returns float voltage [V]
'C','H','E','M','?'/ 'C','H','E','M',' ','xxx'	Li-ion chemistry	Returns unsigned char value
'C','L','O','W','?'/ 'C','L','O','W',' ','xxx'	Relay under voltage switch off	Returns float voltage [V]
'C','R','E','F','?'/ 'C','R','E','F',' ','xxx'	Reference calibration value	Returns float voltage [V](4.996 typ.)
'O','D','D','C','?'/ 'O','D','D','C',' ','xxx'	Odd cells calibration coefficient	Returns float value (+/-0.00003 typ.)
'C','H','A','C','?'/ 'C','H','A','C',' ','xxx'	Charging coefficient (0-3C)	Returns float value 0-3.0 (default 0.6)
'D','C','H','C','?'/ 'D','C','H','C',' ','xxx'	Discharging coefficient (0-3C)	Returns float value 0-3.0 (default 1.5)
'E','A','V','C','?'/ 'E','A','V','C',' ','xxx'	Even cells calibration coefficient	Returns float value (+/-0.00003 typ.)
'S','O','C','H','?'/ 'S','O','C','H',' ','xxx'	Charger SOC hysteresis	Returns float value 0 - 0.99
'S','I','S','N','?'/ 'S','I','S','N',' ','xxx'	Number of SI devices on the bus	Returns unsigned char value (default 1)
'M','A','X','C','?'/ 'M','A','X','C',' ','xxx'	Max allowed charge current per SI device	Returns float current [A]
'M','A','X','D','?'/ 'M','A','X','D',' ','xxx'	Max allowed discharge current per SI device	Returns float current [A]

Parameter accepted and changed value is responded with 'SET' answer.

Example: proper byte message for 'LCD1?' instruction for BMS address 1 is:

```
<0x55><0x01><0x00><0x05><0x4C><0x43><0x44><0x31><0x3F><0x46><0xD0><0xAA>
```

RS-485 message are executed when the microprocessor is not in interrupt routine so a timeout of 350 ms should be set for the answer to arrive. If the timeout occurs the message should be sent again. Parameters are sent back in ASCII, while the arrays are sent back in float/char little endian format.

CAN communication protocol:

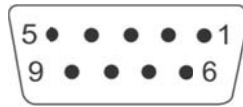

Figure 10: CAN DB9 connector front view.

Table 5: CAN DB9 connector pin designator.

Pin	Designator
1	TERMINATION
2	CANL +TERMINATION
3	GND
4	
5	-
6	GND
7	CANH
8	-
9	

Bit-rate: 500 kbs

Split termination used inside BMS - **terminate pins 1 and 2 if CAN is not in use to prevent BMS reset.** Additional RJ45 connector with 120 Ohms across CANL and CANH is used for SI side CAN bus termination.

11-bit identifiers: 0x351, 0x355, 0x356, 0x35A, 0x35B, 0x35E, 0x35F

Default settings TX only

8 byte message structure:

Table 6: CAN message 0x351 structure description.

Byte	Description	Type	Property
1	Charge voltage low byte	Unsigned integer	LSB = 0.1 V
2	Charge voltage high byte		
3	Max charging current low byte	Signed integer	LSB = 0.1 A
4	Max charging current high byte		
5	Max charging current low byte	Signed integer	LSB = 0.1 A
6	Max charging current high byte		
7	Discharge voltage low byte	Unsigned integer	LSB = 0.1 V
8	Discharge voltage high byte		

Table 7: CAN message 0x355 structure description.

Byte	Description	Type	Property
1	SOC low byte	Unsigned integer	LSB = 1 %
2	SOC high byte		
3	SOH low byte	Unsigned integer	LSB = 1 %
4	SOH high byte		
5	SOC high definition low byte	Unsigned integer	LSB = 0.01 %
6	SOC high definition high byte		

Table 8: CAN message 0x356 structure description.

Byte	Description	Type	Property
1	Battery voltage low byte	Signed integer	LSB = 0.01 V
2	Battery voltage high byte		
3	Battery current low byte	Signed integer	LSB = 0.1 A
4	Battery current high byte		
5	Battery temperature low byte	Signed integer	LSB = 0.1 °C

6	Battery temperature high byte		
---	-------------------------------	--	--

Table 9: CAN message 0x35A structure description.

Byte	Description	Type	Property
1	Alarm byte 1	Unsigned char	Bit orientated Alarm structure
2	Alarm byte 2	Unsigned char	
3	Alarm byte 3	Unsigned char	
4	Alarm byte 4	Unsigned char	
5	Warning byte 1	Unsigned char	Bit orientated Warning structure
6	Warning byte 2	Unsigned char	
7	Warning byte 3	Unsigned char	
8	Warning byte 4	Unsigned char	

CAN messages are sent each measuring cycle with 210 ms interval between.

BMS Unit start procedure:

When the BMS unit is turned ON it commences the test procedure. BMS checks if the user tries to uplod a new firmware by turning on the Power LED. After the timeout Red error LED turns on to signal the system's test procedure. The procedure starts by testing balancing switches, BMS address and cells number, temperature sensor/s detection, self calibration, EEPROM memory parameters, buzzer and internal relay. The test completes in 10 seconds. In case of no Errors red LED turns off and the BMS unit starts working in normal mode.

In case of Address = 0 or cell number < 4, error 6 informs the user to properly set the DIP switches. BMS has to be turned off before the pins are changed.

In case if the BMS does not detect any temperature sensors on the bus, error 8 appears.

Error 10 indicates that the self-calibration routine detected error while calibrating due to reference failure. Error 14 indicates EEPROM data corruption. Error 15 indicates balancing transistor/s failure.

Pre-charge Circuit:

Pre-charge circuit is used to fill the input capacitors of the Sunny Island. When the BMS turns the internal relay, battery voltage starts to charge the capacitors via 33 Ohm power resistors inside the pre-charge circuit. After 4 s, the contactor is turned ON. When the BMS encounters an error and the contactor should be turned OFF, it sends the Alarm via CAN bus so the Sunny Island can start Stand-by or Turn-off procedure prior of contactor turning OFF. Figure 11 below shows how to connect the pre-charge circuit in the system.

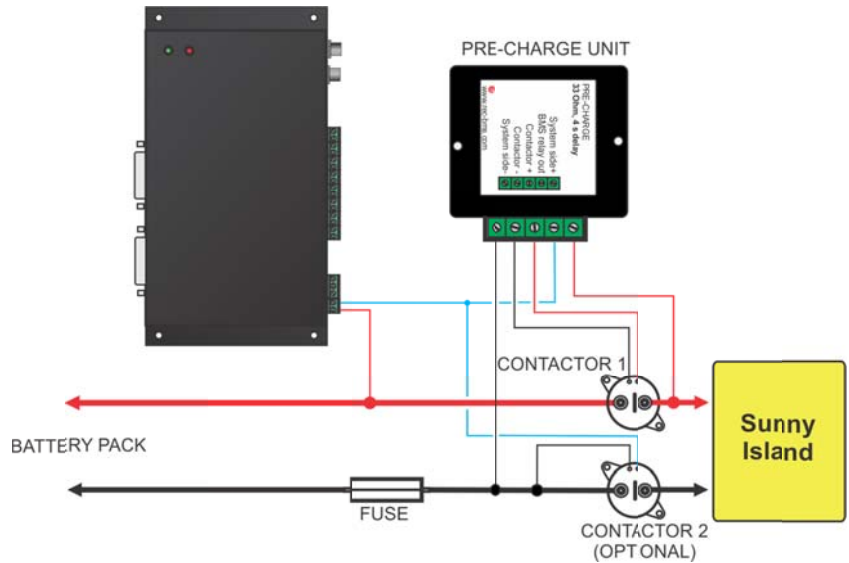

Figure 11: Pre-charge circuit connection schematics.

BMS Unit LED indication:

Power LED (green) is turned on in 2 s intervals, if the BMS is powered. Error LED (red) is turned on in case of system error.

Cell voltage measurement:

Cell voltages are measured every second. The cell measurement algorithm performs several measurements to digitally filter the influence of 50, 60, 100 and 120 Hz sinus signal. Each cell voltage is measured after the balancing fuse, in case the fuse blows BMS signals error 10 to notify the user.

BMS cell balancing:

Cells are balanced passively by a 4.3 Ω power resistor. Since the balancing resistors dissipate heat, an additional temperature measurement is placed inside the enclosure of the BMS unit to prevent overheating the electrical circuit. If the BMS temperature rises above the set threshold, charging and balancing is stopped. BMS error 5 is indicated until the temperature drops under the set hysteresis of 5 °C.

Balancing START voltage:

If errors 2, 4, 5, 8, 10, 12 are not present, highest cell voltage rises above Balancing START voltage and current is > 0.2 A (charging stage) the BMS initiates balancing algorithm. A weighted cell voltage average is determined including cells’ DC internal resistance. Balancing algorithm calculates the voltage above which the cells are balanced. The lowest cell voltage is taken into account determining balancing voltage.

Balancing END voltage:

If errors 2, 4, 5, 8, 10, 12 are not present, the cells above balancing END voltage are balanced regardless the battery pack current.

Cell internal DC resistance measurement:

Cell internal DC resistance is measured as a ratio of a voltage change and current change in two sequential measurement cycles. If the absolute current change is above 15 A, cells internal resistance is calculated. Moving average is used to filter out voltage spikes errors.

Battery pack temperature measurement:

Battery pack temperatures are measured by Dallas DS18B20 digital temperature sensors. Up to four sensors can be used in parallel. BMS should be turned off before adding additional sensors. If the temperature sensors wiring is placed near the power lines shielded cables should be used.

BMS current measurement:

A low-side precision shunt resistor for current measurement is used. A 4-wire Kelvin connection is used to measure the voltage drop on the resistor. As short as possible **shielded cable** should be used to connect the power shunt and BMS. The battery pack current is measured every second. A high precision 18-bit Sigma-Delta ADC is used to filter out the current spikes. The first current measurement is timed at the beginning of the cell measurement procedure for a proper internal DC resistance calculation. Shunt connection is shown in Fig. 12.

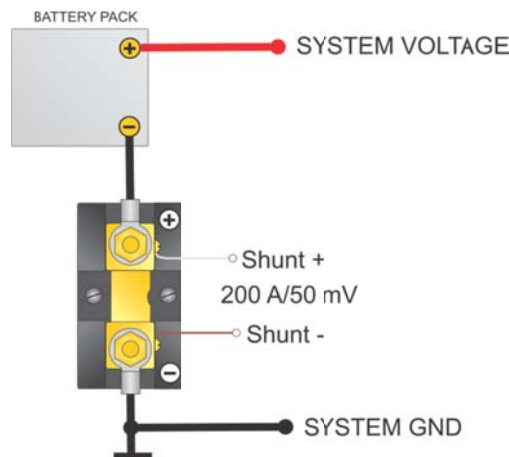

Figure 12: Shunt resistor connection.

Table 10: Shunt resistor connection.

Pin	Signal
1	+ Shunt
2	Shield
3	- Shunt

Voltage-to-current coefficient:

Different size and resistance shunts can be used, since the voltage-to-current coefficient can be changed in the BMS Control software as 'I','O','J','A',' ','xxxxx'

Current is calculated by the voltage drop at the shunt resistor. 1 LSB of the 18-bit ADC represents different current values according to the shunt resistance. The LSB coefficient can be calculated as:

$$k_{LSB} = 0.01171875 \cdot \frac{0.05 \text{ V}}{300 \text{ A}} \cdot \frac{I_{\text{currentx}}}{V_{\text{dropx}}}$$

where the V_{dropx} represents the voltage drop on different shunt resistor at current $I_{currentx}$.

ADC has a pre-set gain of 8. With a maximum input voltage difference of 0.256 V.

Battery pack SOC determination:

SOC is determined by integrating the charge in-to or out of the battery pack. Different Li-ion chemistries may be selected:

Table 11: Li-ion chemistry designators.

Number	Type
1	Li-Po Kokam High power
2	Li-Po Kokam High capacity
3	Winston/Thunder-Sky/GWL LiFePO4
4	A123
5	Li-ion NMC/ $LiMn_2O_4$

Temperature and power correction coefficient are taken into consideration at the SOC calculation. Li-Po chemistry algorithms have an additional voltage to SOC regulation loop inside the algorithm. Actual cell capacity is recalculated by the number of the charging cycles as pointed out in the manufacturer’s datasheet.

When BMS is connected to the battery pack for the first time, SOC is set to 50 %. SOC is reset to 100 % at the end of charging. Charging cycle is added if the minimum SOC of 35% or less was reached in the cycle.

Battery pack’s charging algorithm:

Calculated maximum charging current is sent to the Sunny Island by CAN communication in every measurement cycle. When the BMS starts/recovers from the error maximum allowed charging current is set. It is calculated as charging coefficient ('C','H','A','C') x Battery capacity. If this value is higher than maximum charging current per device ('M','A','X','C') x number of devices ('S','I','S','N'), maximum charging current is decreased to this value. When the highest cell reaches the voltage interval between balance voltages start and balance voltage end, charging current starts to ramp down to 1 A x number of devices until the last cell rises to the End of Charge Voltage. When all the cells reach End of Charge voltage Maximum charging current is set to 0 A and Charge enable optocoupler is turned off, End of Charge SOC hysteresis and End of charging cell voltage hysteresis are set. Some of the BMS Errors also set the charging current/charge enable optocoupler to 0 A (See System Errors indication chapter).

SOC is calibrated to 95 % at the arithmetic mean value between balance voltage start and balance voltage end.

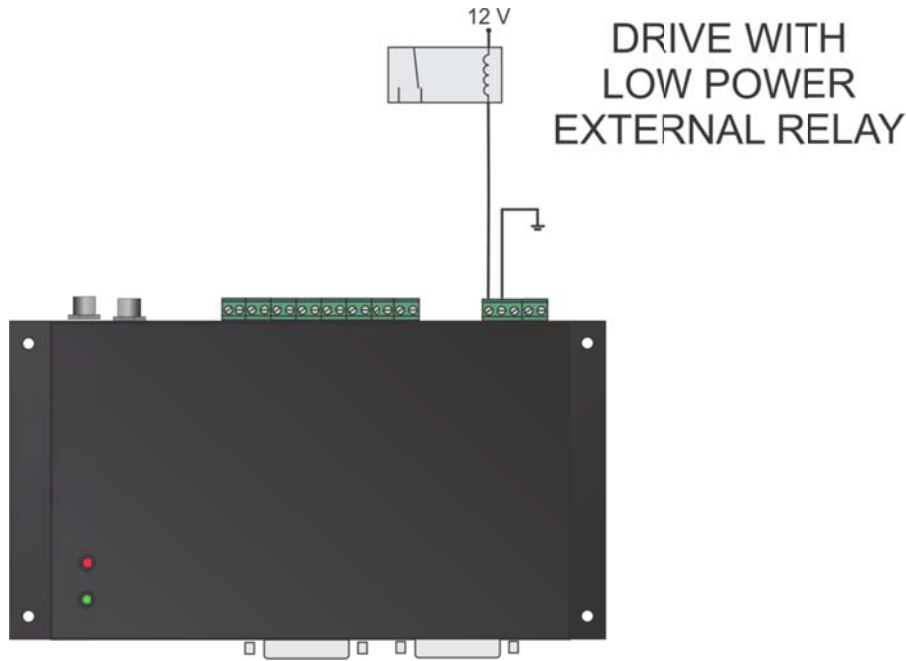

Figure 13: External relay with 12 V coil connection schematics.

Battery pack’s discharging algorithm:

Calculated maximum discharging current is sent to the Sunny Island by CAN communication in every measurement cycle. When the BMS starts/recovers from the error or from Discharging SOC hysteresis, maximum allowed discharging current is set. It is calculated as discharging coefficient ('D','C','H','C') x Battery capacity. If this value is higher than maximum discharging current per device ('M','A','X','D') x number of devices ('S','I','S','N'), maximum discharging current is decreased to this value. When the lowest cell is discharged below the set threshold 'C','L','O','W' (2.9V), the maximum discharging current starts to decrease down to 0.05 C (5 % of Capacity in A). After decreasing down, maximum allowed discharging current is set to 0 A. SOC is set to 3%. 5 % Discharging SOC hysteresis is set. If the cell discharges below Minimum Cell voltage ('C','M','I','N'), BMS signals Error 2 and SOC is reset to 0 %. Sunny Island should be then reset manually.

SOC is calibrated to 10 % when the open circuit voltage of the lowest cell reaches 3.1 V. This threshold is temperature compensated. This feature is added to start the generator when the battery pack is almost empty.

System Error indication:

System errors are indicated with red error LED by the number of ON blinks, followed by a longer OFF state.

Table 12: BMS error states.

Number of ON blinks	ERROR	BMS	OWNER
1	Single or multiple cell voltage is too high (cell over voltage switch-off).	BMS will try to balance down the problematic cell/cells to safe voltage level (4 s error hysteresis + single cell voltage hysteresis is applied). Internal relay is opened, charging is disabled, discharging is enabled.	<ul style="list-style-type: none"> Wait until the BMS does its job.

BATTERY MANAGEMENT SYSTEM 1Q FOR SMA SI

2	Single or multiple cell voltage is too low (cell under voltage protection switch-off).	BMS will try to charge the battery (4 s error hysteresis +single cell voltage hysteresis is applied). Internal relay is opened to disable discharging, charging is enabled, discharging is disabled.	<ul style="list-style-type: none"> • Plug in the charger.
3	Cell voltages differs more than set.	BMS will try to balance the cells (4 s error hysteresis + 20 mV voltage difference hysteresis). Internal relay is closed, charging is enabled, discharging is enabled.	<ul style="list-style-type: none"> • Wait until the BMS does its job. If the BMS is not able to balance the difference in a few hours, contact the service.
4	Cell temperature is too high (over temperature switch-off).	Cells temperature or cell inter-connecting cable temperature in the battery pack is/are too high. (4 s error hysteresis 2°C hysteresis). Internal relay is opened, charging is disabled, discharging is disabled.	<ul style="list-style-type: none"> • Wait until the pack cools down.
5	BMS temperature is too high (BMS over temperature switch-off).	Due to extensive cell balancing the BMS temperature rose over upper limit (4 s error hysteresis + 5 °C temperature hysteresis). Internal relay is closed, charging is enabled, discharging is enabled.	<ul style="list-style-type: none"> • Wait until the BMS cools down.
6	Number of cells, address is not set properly.	Number of cells at the back of the BMS unit was changed from the default manufacturer settings. Internal relay is opened, charging is disabled, discharging is disabled.	<ul style="list-style-type: none"> • Set the proper number of cells, address and restart the BMS.
7	The temperature is too low for charging (under temperature charging disable).	If cells are charged at temperatures lower than operating temperature range, cells are aging much faster than they normally would, so charging is disabled (2 °C temperature hysteresis). Internal relay is opened, charging is disabled, discharging is enabled.	<ul style="list-style-type: none"> • Wait until the battery's temperature rises to usable range.
8	Temperature sensor error.	Temperature sensor is un-plugged or not working properly (4 s error hysteresis). Internal relay is opened, charging is disabled, discharging is disabled.	<ul style="list-style-type: none"> • Turn-off BMS unit and try to re-plug the temp. sensor. If the BMS still signals error 8, contact the service. The temperature sensors should be replaced.
9	Communication error.	RS-485 Master-Slave communication only.	

BATTERY MANAGEMENT SYSTEM 1Q FOR SMA SI

10	Cell in short circuit or BMS measurement error.	<p>Single or multiple cell voltage is close to zero or out of range, indicating a blown fuse, short circuit or measuring failure (20 s error hysteresis + 10 mV voltage difference hysteresis).</p> <p>Internal relay is opened, charging is disabled, discharging is disabled.</p>	<ul style="list-style-type: none"> • Turn-off the BMS and check the cells connection to the BMS and fuses. Restart the BMS. • If the same error starts to signal again contact the service.
11	Main relay is in short circuit.	<p>If the main relay should be opened and current is not zero or positive, the BMS signals error 11. When the error is detected, the BMS tries to un-shorten the main relay by turning it ON and OFF for three times.</p> <p>Internal relay is opened, charging is disabled, discharging is disabled.</p>	<ul style="list-style-type: none"> • Restart the BMS unit. If the same error starts to signal again contact the service.
12	Error measuring current.	<p>Current sensor is disconnected or not working properly.</p> <p>Internal relay is opened, charging is disabled, discharging is disabled.</p>	<ul style="list-style-type: none"> • Turn-off the BMS and check the sensor connections, re-plug the current sensor connector. Turn BMS back ON. If the BMS still signals error 12, contact the service.
13	Wrong cell chemistry selected.	<p>In some application the chemistry pre-set is compulsory.</p> <p>Internal relay is opened, charging is disabled, discharging is disabled.</p>	<ul style="list-style-type: none"> • Use PC Control Software to set proper cell chemistry.
14	Wrong EEPROM value.	<p>EMI or other interference caused EEPROM data to change. Default settings are programmed-in.</p> <p>Contactors are closed, charging is enabled, discharging is enabled.</p>	<ul style="list-style-type: none"> • Use PC interface to set proper parameters.
15	Balancing transistors failure	<p>Single or multiple transistors for balancing failure detection</p> <p>Contactors are closed, charging is enabled, discharging is enabled.</p>	<ul style="list-style-type: none"> • Restart the BMS unit. If the same error starts to signal again contact the service.

BMS Unit dimensions:

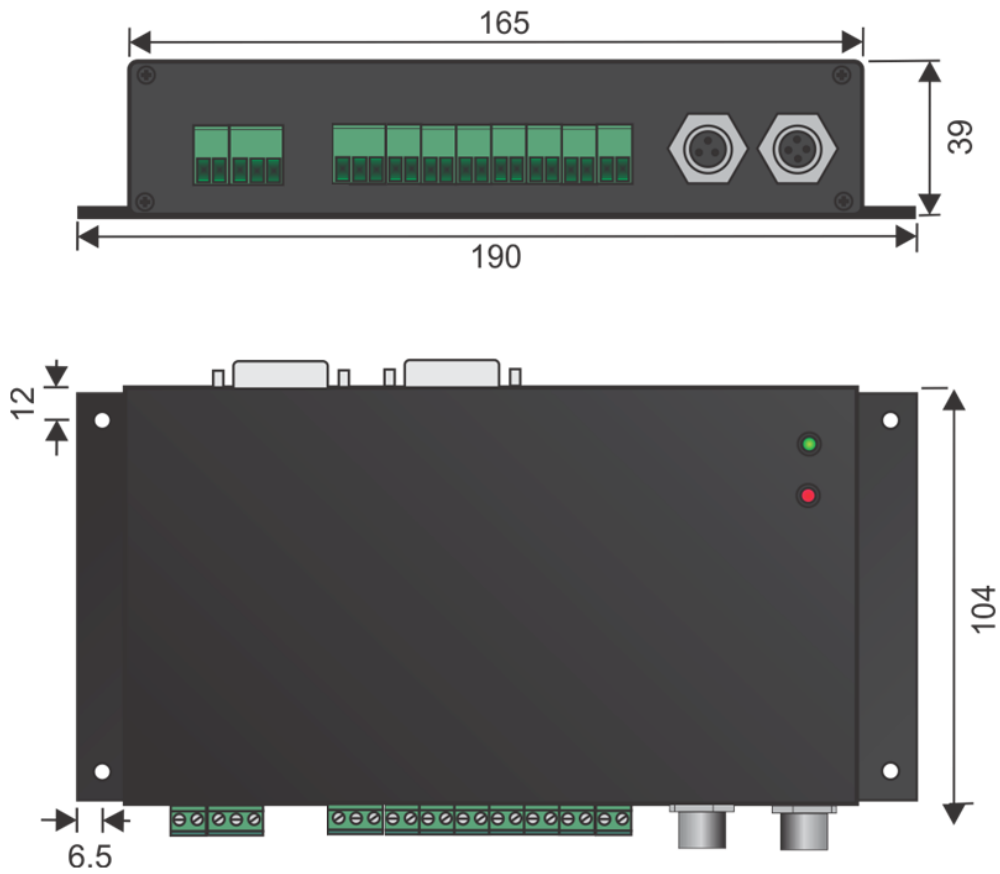

Figure 14: BMS dimensions.

BMS unit can be supplied without the enclosure, if an application is weight or space limited. The dimensions of the BMS without the enclosure are 160 mm x 100 mm x 27 mm. Sufficient contact surface for cooling the balancing resistors should be provided (aluminum recommended). The PCB has four 3.2 mm mounting holes.