



# 产品规格书

方形锂离子电池

型号: L135F68

## 修订履历

版次	日期	变更内容	备注
A0	2017.3.27	首版	

编制	校对	审核	批准	会签
雷利亮 2017.3.27	刘吉云 2017.3.27	郭建峰 2017.3.27	潘芳芳 2017.3.27	乔景锋 杨丽军 2017.3.27



中航锂电(洛阳)有限公司  
CHINA AVIATION LITHIUM BATTERY CO., LTD.

# 产品规格书 Specification

版本号 Version Number: A/0  
发行日期 Issue Date: 2017-3-27

# 产品规格书 Product Specification

方形锂离子电池

Prismatic lithium Ion Battery

型号: L135F68

Model: L135F68

中航锂电(洛阳)有限公司  
**China Aviation Lithium Battery (Luoyang) Co., Ltd.**



## 目 录 Contents

术语定义 Terms & Definition .....	I
1. 适用范围 Scope .....	3
2. 产品类型 Product Type .....	3
3. 单体电池尺寸 Cell Dimensions .....	3
4. 产品性能 Product Performance .....	4
5. 运输注意事项 Precautions for Transportation .....	14
6. 贮存注意事项 Precautions for Storage .....	15
7. 充电注意事项 Precautions for Charging .....	15
8. 放电注意事项 Precautions for Discharging .....	16
9. 电池操作注意事项 Cautions of Battery Operation .....	17
10. 紧急情况处理 Emergency Treatment .....	19
11. 其它事项 Others .....	20



## 术语定义 Terms & Definition

术语 Terms	定义 Definition
中航锂电 CALB	指中航锂电(洛阳)有限公司。 China Aviation Lithium Battery (Luoyang) Co., Ltd.
产 品 Product	本规格书中的“产品”是指中航锂电生产的 L135F68 (3.2V) 可充电磷酸铁锂电池。 "Product" in this specification refers to L135F68 (3.2V) rechargeable lithium iron phosphate battery produced by CALB.
客 户 Customer	“客户”是指购买本规格书所述产品的公司、企业或个人。 "Customer" means the companies, enterprises or individuals who purchase the products described in this specification.
室 温 Room Temperature	25±2℃。
电池温度 Cell Temperature	电池正极极柱温度。 The temperature of the cell positive terminal.
充电倍率 Charge Rate (C-Rate)	电池在规定的时间内放出其额定容量时所需要的电流值，它在数据值上等于电池额定容量的倍数，通常以字母 C 表示。 The current value that the battery need to discharge its rated capacity in a stated time, which equal to a multiple of the rated capacity of the battery on the data value, usually expressed with the letter "C".
循环寿命 Cycle life	二次电池在反复充放电的使用下，电池的容量会逐渐下降，通常以该电池的额定容量作为标准，电池容量降到其 80% 的充放电次数，称为循环寿命。 With the repeated charging and discharging, the battery's capacity will gradually decline. Usually the rated capacity of the battery is a standard, the number of charge-discharge cycles a battery can go through before it reaches 80% of its rated capacity called cycle life.
开路电压 Open circuit voltage (OCV)	开路电压是指外电路没有电流流过时电池正负极柱之间的电位差。 Open-circuit voltage is the difference of electrical potential between two terminals of a device when disconnected from any circuit.
工作电压 Operating Voltage	工作电压又称放电电压或负荷电压，是指有电流通过外电路时，电池两极间的电位差。工作电压总是低于开路电压，因为电流流过电池内部时，必须克服极化电阻和欧姆内阻所造成的阻力。 Operating voltage, also known as the discharge voltage or load voltage, is defined as the potential difference between the battery terminals when the current transmits through the external circuit. Working voltage is always lower than the open circuit voltage, because when the current transmits through the battery internal, the polarization resistance and ohmic resistance must be overcome.
可恢复容量 Restore capacity	电池储存后，按照本规格书第 4.2.1 和 4.4.1 条所列的标准充放电条件所测得的容量，取值分别按照本规格书第 4.2.1 和 4.4.1 条给出的充放电标准，分别选取 3 次测量的最大值。 After storage, the capacity tested according to the standard charge and discharge conditions listed in section 4.2.1 and 4.4.1, the maximum of 3 measured values were selected as restore capacity.
荷电保持能力 Charge retention capability	电池在一定温度下，储存一定时间后，放电所获得的容量与额定容量之比的百分数。 The percentage of the discharge capacity and rated capacity after the battery stored in a certain temperature and time condition.



容量恢复能力 Capacity recovery capability	电池在一定温度下，储存一定时间后再行充电，其后放电容量与额定容量之比的百分数。 The percentage of the discharge capacity and rated capacity with recharging after the battery stored in a certain temperature and time.
产品供货合同 Product supply contract	中航锂电和客户共同签订的有关本规格书产品的交易条款。 Terms of the deal signed by CALB and clients about the specifications of the product.
标准充电 Standard Charging	本规格书第 4.2.1 条所述的充电模式。 Charge mode described in section 4.2.1.
标准放电 Standard Discharging	本规格书第 4.4.1 条所述的放电模式。 Discharge mode described in section 4.4.1.
荷电状态 State of charge (SOC)	电池剩余电量百分比，也是电池一个重要的参数，只有准确估算电池 SOC 才能有效提高电池利用效率、保证电池的使用寿命和安全。 The percentage of remaining energy. Only with estimating the battery SOC accurately can improve the utilization efficiency of the battery, and ensure the battery life and safety.
电池管理系统 Battery Management System (BMS)	由电池电子部件和电池控制单元组成的电子装置。电池电子部件是采集电池单体(集成)或电池模块(集成)的与电和热相关的数据，并将这些数据提供给电池控制单元的电子装置。电池控制单元是控制或管理电池系统电或热性能，并可以与车辆上的其他控制单元进行信息交互的电子控制部件。 The electronic device is composed of electronic components and battery control units. The electronic component is to collect the electrical and heat related data of cell (integration) or battery module (integrated), and supply the data to the battery control unit of the electronic device. Battery control unit is a battery management control system which controls the electrical or thermal properties, and exchanges information with other control units on the vehicle.
测量单位 Units of measurement	“V” (Volt) 伏特，电压单位 “V” (Volt) ,Unit of voltage
	“A” (Ampere) 安培，电流单位 “A” (Ampere) ,Unit of current
	“Ah” (Ampere-Hour) 安培-小时，电荷单位 “Ah” (Ampere-Hour) ,Unit of electric charge
	“Wh” (Watt-Hour) 瓦特-小时，能量单位 “Wh” (Watt-Hour) ,Unit of energy
	“mΩ” (MilliOhm) 毫欧姆，电阻单位 “mΩ” (MilliOhm) ,Unit of resistance
	“℃” (degree Celsius) 摄氏度，温度单位 “℃” (degree Celsius) ,Unit of temperature
	“mm” (millimeter) 毫米，长度单位 “mm” (millimeter) ,Unit of length
	“s” (second) 秒，时间单位 “s” (second) ,Unit of time
	“Hz” (Hertz) 赫兹，频率单位 “Hz” (Hertz) ,Unit of frequency



## 1. 适用范围 Scope

本产品规格书描述了中航锂电生产的 L135F68 可充电磷酸铁锂电池的产品性能指标、技术要求及安全注意事项。

This specification covers the performance indexes, technical requirements and safety issue of the L135F68 rechargeable lithium iron phosphate cell manufactured by CALB.

## 2. 产品类型 Product Type

2.1 产品名称：磷酸铁锂电池

Product Name: Lithium iron phosphate cell

2.2 型号规格：L135F68

Specification: L135F68

## 3. 单体电池尺寸 Cell Dimensions

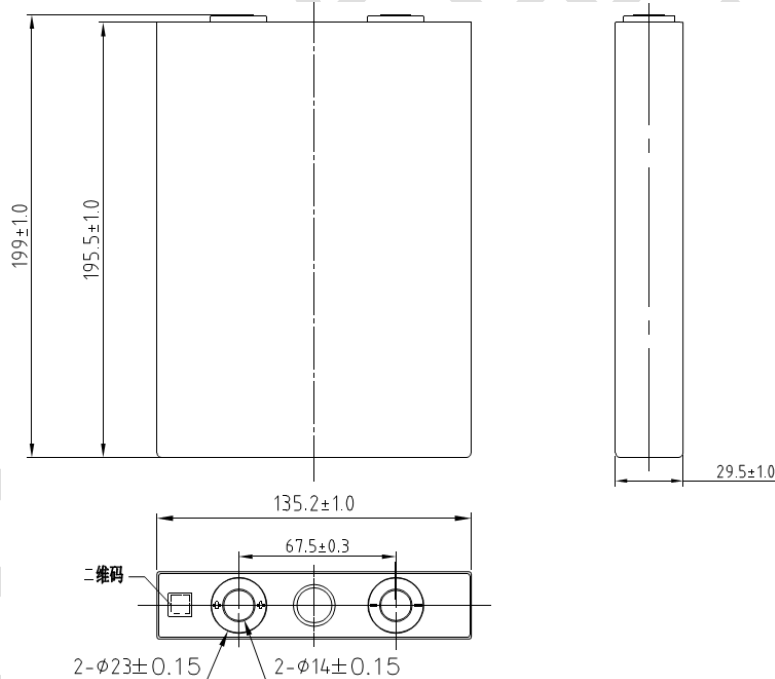

项目 Items	描述 Description	尺寸 (mm) Dimensions (mm)
L	长度 Length	135.2±1.0
W	宽度 Width	29.5±1.0
H	高度 Height	199.0±1.0



# 产品规格书 Specification

## 4. 产品性能 Product Performance

### 4.1 技术参数 Technical Parameters

序号 NO.	项目 Items	参数说明 Parameter	备注 Remarks
1	额定容量 Nominal Capacity	68Ah	标准放电 Standard Discharge
2	最小容量 Minimal Capacity	68Ah	标准放电 Standard Discharge
3	工作电压 Work Voltage	2.5~3.65V	室温 Room Temperature 注: 不同温度工作电压见4.2.5及4.4.7 Note: Work voltage at different temperature refers to section 4.2.5 and 4.4.7
4	内阻 (Ac. 1kHz) Internal Resistance (Ac. 1kHz)	0.2~0.6mΩ	新电池、30%SOC Fresh Cell、30%SOC
5	充电时间 Charging Time	标准充电 Standard Charge	参考值 Reference Value
		快速充电 Fast Charge	
6	工作温度 Operating Temperature	充电温度 Charging Temperature	参考第 4.2 节 Refer to section 4.2
		放电温度 Discharging Temperature	参考第 4.4 节 Refer to section 4.4
7	电池重量 Weight	1.60±0.15kg	
8	壳体材料 Shell Material	铝 Aluminium	

### 4.2 充电模式 Charging Model

序号 NO.	参数 Parameter	产品规格 Specifications	备注 Remarks
4.2.1	标准充电模式 Standard Charging Model	室温下, 以20.4A恒流持续充电至单体电池电压3.65V, 然后在3.65V下恒压持续充电直至电流下限≤3.4±0.5A At room temperature, charged to 3.65V at a constant current of 20.4A, and then, changed continuously with constant voltage of 3.65V until the current was not more than 3.4±0.5A.	



# 产品规格书 Specification

4.2.2	标准充电温度 Standard Charging Temperature	25±2℃	电池温度 Cell Temperature
4.2.3	绝对充电温度 Absolute Charging Temperature	-5~55℃	无论电池处在何种充电模式，一旦发现电池温度超过绝对充电温度范围，即停止充电 No matter what the charging model is, once the temperature of the cell is above the absolute charging temperature, charging should be stopped.
4.2.4	绝对充电电压 Absolute Charging Voltage	最大3.8V Maximum 3.8V	无论电池处在何种充电模式包括脉冲充电状态，一旦发现电池电压超过绝对充电电压范围，即停止充电 No matter what the charging model is, including pulse charging, once the voltage of the cell is above the absolute charging voltage, charging should be stopped.

#### 4.2.5 不同温度下充电电流限制 Charging Current Limit at Different Temperature

电池温度范围 Cell temperature range	T < -5℃	-5 ≤ T ≤ 0℃	0 < T ≤ 5℃	5 < T ≤ 10℃	10 < T ≤ 25℃	25 < T ≤ 45℃	45 < T ≤ 50℃	50 < T ≤ 55℃	T > 55℃
允许最大充电电流 Maximum charging current allowed	不允许 Not allowed	0.05C	0.1C	0.2C	0.5C	1C	0.5C	0.2C	不允许 Not allowed
充电截止电压 Charging voltage limit		3.60V	3.60V	3.60V	3.65V	3.65V	3.65V	3.60V	

#### 4.3 允许最大脉冲充电电流 Maximum pulse charging current allowed

产品使用过程中，再生制动过程的脉冲电流对电池具有充电效果。不同温度条件下的允许最大脉冲充电电流和持续时间必须严格遵守下表所列的所有充电状态以及电池温度等条件。违反下列充电条件可能会造成电池永久性的损坏并进而免除中航锂电的产品质量责任。

During the process of product being used, pulse current created in regenerative braking can recharge the battery. Maximum charging current allowed and the pulse duration in different temperature conditions must strictly observe the conditions listed in the following table. Violating the described conditions may cause permanent damage to the battery and thus is exempt from the responsibility of CALB for product quality.

不同 SOC 和温度条件下，允许最大脉冲充电电流和持续时间如下表所示：

In different SOC and temperature conditions, the maximum values of charging current allowed and the pulse duration are shown in the following table:



SOC	电池温度 Cell Temperature					
	$T < -5^{\circ}\text{C}$	$-5 \leq T \leq 0^{\circ}\text{C}$	$0 < T \leq 10^{\circ}\text{C}$	$10 < T \leq 25^{\circ}\text{C}$	$25 < T \leq 45^{\circ}\text{C}$	$45 < T \leq 55^{\circ}\text{C}$
$\geq 95\%$	不允许 Not allowed	不允许 Not allowed	不允许 Not allowed	不允许 Not allowed	不允许 Not allowed	不允许 Not allowed
$> 90\%$	不允许 Not allowed	不允许 Not allowed	不允许 Not allowed	0.8C/10s	1C/10s	0.8C/10s
$> 80\%$	不允许 Not allowed	不允许 Not allowed	0.8C/10s	1C/10s	1.5C/10s	1C/10s
$> 70\%$	不允许 Not allowed	0.8C/10s	1C/10s	1.5C/10s	2C/10s	1.5C/10s
$\leq 70\%$	不允许 Not allowed	1C/10s	1.5C/10s	2C/10s	2C/10s	1.5C/10s

每次制动充电后，电池需要有段休眠时期，时间应等于或长于脉冲充电持续时间。休眠时期内，电池可以处于放电状态，也可以处于零电流不工作状态，也可以处于小电流充电状态，但充电要求不允许超过 4.2.5 允许的范围。

After each brake charging, the battery needs to rest for certain time, which should be equal to or longer than the duration of the pulse charging. During the rest, the battery can be in the discharged state, or in a non-working state, or can be charged in small current, but the charging demand should not exceed the range allowed in 4.2.5.

#### 4.4 放电模式 Discharging Model

序号 NO.	参数 Parameter	产品规格 Specifications	备注 Remarks
4.4.1	标准放电模式 Standard Discharging Model	室温下，以68A恒流持续放电至2.5V At room temperature, discharge to 2.5V at a constant current of 68A.	
4.4.2	最大持续放电电流 Maximum Constant Discharging Current	68A	
4.4.3	最大脉冲放电电流（长脉冲） Maximum Pulse Discharging Current (Long Pulse)	136A	最长时间为3min Maximum duration: 3min
4.4.4	最大脉冲放电电流（短脉冲） Maximum Pulse Discharging Current (Short Pulse)	204A	电池温度低于50℃，且最长放电时间为30s When battery temperature is below 50℃, the maximum discharge can last 30s
4.4.5	标准放电温度 Standard Discharging Temperature	$25 \pm 2^{\circ}\text{C}$	电池温度 Cell Temperature
4.4.6	绝对放电温度 Absolute Discharging Temperature	$-30 \sim 55^{\circ}\text{C}$	无论电池处在何种放电模式，一旦发现电池温度超过绝对放电温度范围即停止放电



No matter what the discharging model is, once the temperature of the cell is above the absolute discharging temperature, discharging should be stopped.

#### 4.4.7 不同温度下放电电流及放电截止电压限制 Discharging Current and Voltage Limit at Different Temperature

电池温度范围 Cell temperature range	$-30 \leq T \leq -20^\circ\text{C}$	$-20 < T \leq -5^\circ\text{C}$	$-5 < T \leq 0^\circ\text{C}$	$0 < T \leq 5^\circ\text{C}$	$5 < T \leq 15^\circ\text{C}$	$15 < T \leq 45^\circ\text{C}$	$45 < T \leq 55^\circ\text{C}$
允许最大放电流 Maximum charging current allowed	0.1C	0.2C	0.3C	0.3C	0.5C	1.0C	0.5C
放电截止电压 Discharging voltage limit	2.0V	2.0V	2.3V	2.5V	2.5V	2.5V	2.5V

#### 4.5 脉冲放电 Pulse Discharging

##### 允许最大脉冲放电电流和持续时间 Minimum Pulse Discharging Current and The Pulse Duration Allowed

SOC	电池温度 Cell Temperature					
	$-30 \leq T \leq -20^\circ\text{C}$	$-20 < T \leq -10^\circ\text{C}$	$-10^\circ\text{C} < T \leq 0^\circ\text{C}$	$0 < T \leq 10^\circ\text{C}$	$10 < T \leq 45^\circ\text{C}$	$45 < T \leq 55^\circ\text{C}$
$\geq 20\%$	0.2C/30s	0.5C/30s	1.0C/30s	2.0C/30s	3.0C/30s	1.0C/30s
$< 20\%$	不允许 Not allowed	不允许 Not allowed	0.5C/30s	1.0C/30s	2.0C/30s	0.5C/30s

每次脉冲放电后，电池需要有段休眠时期，时间应等于或长于脉冲放电持续时间。休眠时期内，电池可以处于充电状态，也可以处于零电流不工作状态，也可以处小电流放电状态，但放电要求不允许超过 4.4.7 允许的范围。

After each pulse discharging, the battery need to rest for certain time, which should be equal to or longer than the duration of the pulse discharging. During the rest, the battery can be in the charging state, or in non-working state, or can be discharged in small current, but the discharging demand should not exceed the range allowed in 4.4.7.

#### 4.6 电性能 Electrical Properties

##### 4.6.1 测试条件 Test Conditions

除另有规定外，试验应在温度为： $25 \pm 5^\circ\text{C}$ ，相对湿度为：25%~85%，大气压力为：86KPa~106KPa 的环境中进行。

Unless otherwise specified, all the experiments should be carried out under ambient temperature:  $25 \pm 5^\circ\text{C}$ , relative



humidity: 25%~85% and atmospheric pressure: 86KPa~106KPa.

#### 4.6.2 测量仪表与设备要求 Requirements of Measuring Instruments and Facilities

检验测试的所有仪表、设备（包括监控和监视试验参数的试验设备和仪器）应按国家有关计量检定规程或有关标准经检定或计量合格，并在有效期内。所有测试仪表、设备应具有足够的精度和稳定度，其精度应高于被测指标精度一个数量级或误差小于被测参数允许误差的三分之一。

All of the measuring instruments and facilities (include the equipments which monitor the test parameters) should be verified and calibrated qualified by relevant Chinese Calibration Regulation or certain standards within the valid date. All the test instruments and equipments should have adequate precision and stability and the precision should be an order higher than the tested indicators or the tolerance should be less than one third of the tested parameters.

#### 4.6.3 性能指标 Performance Criterion

序号 NO.	项目 Items	技术要求 Technical Requirements	测试方法及步骤 Test Methods
1	外观 Appearance	电池应无破损、漏液、油污等缺陷，标识清楚。 No damage, leakage, oil contamination. Legibly marked.	目测法 Visual Inspection
2	室温放电性能 Discharging performance under room temperature	放电容量： Discharging Capacity: 68A 放电时 $\geq 68\text{Ah}$ Discharged at 68A $\geq 68\text{Ah}$	68A 放电容量 Discharge capacity at 68A: 室温下，以 68A 进行放电至下限电压 2.5V，计算放电容量（以 Ah 计）。 It's the capacity (in Ah) when the battery is discharged to 2.5V at 68A at $25\pm 2^\circ\text{C}$ .



# 产品规格书 Specification

3	<p>高低温放电性能 Discharging characteristics under high and low temperatures</p>	<p>放电容量: Discharging Capacity: a) 55℃时≥98%初始容量; Discharged at 55 °C ≥98% initial capacity; b) -20℃时≥70%初始容量; Discharged at -20°C ≥70% initial capacity;</p>	<p>高温放电容量: Discharge capacity at high-temperature: a) 电池标准充电; Standard charge; b) 在 55±2℃条件下搁置 5h; Be set aside for 5h at 55±2°C; c) 在 55±2℃条件下以 68A 放电至终止电压 2.5V, 计算放电容量 (以 Ah 计)。 Discharging the battery to 2.5V at 68A at 55±2°C, calculate the capacity.  低温放电容量试验按如下步骤进行: Discharge capacity test at low-temperature: a) 电池标准充电; Standard charge b) 在-20±2℃条件下搁置 24h; Be set aside for 24h at -20±2°C; c) 在-20±2℃条件下以 68A 放电至终止电压 2.0V, 计算放电容量 (以 Ah 计)。 Discharging the battery to 2.5V at 68A at -20±2°C, calculate the capacity</p>
4	<p>倍充性能 Rate charge Performance</p>	<p>容量≥97% 初始容量; Capacity ≥ 97% initial capacity;</p>	<p>a) 室温下蓄电池以68A放电至终止电压2.5V, 静置1h; Under room temperature, discharge it at 68A to cut-off voltage 2.5V; b) 室温下, 以136A恒流持续充电至单体电池电压 3.65V, 然后在3.65V下恒压持续充电直至电流下限 ≤3.4±0.5A, 静置1h; Under room temperature, charged to 3.65V at a constant current of 136A, and then, changed continuously with constant voltage of 3.65V until the current was not more than 3.4±0.5A. Put aside for 1h; c) 室温下, 蓄电池以68A电流放电至终止电压2.5V; Under room temperature, discharge it at 68A to cut-off voltage 2.5V; d) 计算放电容量(以 Ah 计)。 Calculate recovery capacity (in Ah).</p>
5	<p>倍放性能 Rate Discharge Performance</p>	<p>电池容量 ≥ 95% 初始容量; Capacity ≥ 95% initial capacity;</p>	<p>a) 电池标准充电; Standard charge; b) 室温下, 电池以204A电流放电至终止电压2.5V; Under room temperature, charge with 204A, to cut-off voltage 2.5V; c) 计算放电容量(以Ah计)。 Calculate recovery capacity (in Ah).</p>



# 产品规格书 Specification

6	<p>荷电保持与容量恢复能力 Charge retention and capacity recoverable capability</p>	<p>荷电保持率<math>\geq 96\%</math>初始容量; Charge retention<math>\geq 96\%</math> initial capacity; 容量恢复率<math>\geq 97\%</math>初始容量; Capacity recovery<math>\geq 97\%</math> initial capacity;</p>	<p>1、室温荷电保持与容量恢复能力: Charge retention and capacity recoverable capability under room temperature:</p> <p>a) 电池标准充电; Standard charge;</p> <p>b) 在 <math>25\pm 5^{\circ}\text{C}</math> 条件下储存 28 天; Stored for 28 days at <math>25\pm 5^{\circ}\text{C}</math>;</p> <p>c) 室温下, 以 68A 放电至终止电压, 计算荷电保持容量 (以 Ah 计); Under room temperature, discharge it at 68A to cut-off voltage and calculate retention capacity (in Ah).</p> <p>d) 电池再进行标准充电; Then standard charged again;</p> <p>e) 室温下, 以 68A 放电至终止电压, 计算恢复容量 (以 Ah 计)。 Under room temperature, discharge it at 68A to cut-off voltage and calculate recovery capacity (in Ah).</p> <p>2、高温荷电保持与容量恢复能力: Charge retention and capacity recoverable capability under high temperature:</p> <p>a) 电池标准充电; Standard charge;</p> <p>b) 在 <math>55\pm 2^{\circ}\text{C}</math> 条件下储存 7 天; Stored for 7 days at <math>55\pm 2^{\circ}\text{C}</math>;</p> <p>c) 室温下搁置 5h 后, 以 68A 放电至终止电压 2.5V, 计算荷电保持容量 (以 Ah 计); Under room temperature, Put aside for 5h, discharge with 68A to cut-off voltage 2.5V and calculate retention capacity (in Ah);</p> <p>d) 电池再进行标准充电; Then standard charged again;</p> <p>e) 室温下, 以 68A 放电至终止电压 2.5V, 计算恢复容量 (以 Ah 计)。 Under room temperature, discharge with 68A to cut-off voltage 2.5V and calculate recovery capacity (in Ah).</p>
---	---	---	--



# 产品规格书 Specification

7	储存性能 Storage Performance	可恢复容量 $\geq 95\%$ 初始容量 Restorable capacity $\geq 95\%$ initial capacity	<p>a) 电池标准充电; Standard charge;</p> <p>b) 以 68A 电流放电 30min。 Discharge 30 min at 68A current;</p> <p>c) 45<math>\pm</math>2<math>^{\circ}</math>C 温度储存 28 天; storage for 28 days at 45<math>\pm</math>2<math>^{\circ}</math>C;</p> <p>d) 室温下搁置 5h; Under room temperature, put aside for 5h;</p> <p>e) 电池再进行标准充电; Standard charge again;</p> <p>f) 室温下, 以 68A 电流放电至终止电压 2.5V。 Under room temperature, discharge it at 68A to cut-off voltage 2.5V;</p> <p>g) 计算放电容量 (以 Ah 计)。 Calculate retention capacity (in Ah).</p>
8	循环寿命 Cycle Life	$\geq 3000$ 次 $\geq 3000$ cycles	<p>a) 室温下, 以 68A 恒流持续充电至 3.65V, 然后在 3.65V 下恒压持续充电直至电流下限 <math>\leq 3.4 \pm 0.5A</math>, 静置 10min; Under room temperature, charge to 3.65V at a constant current of 68A, and then, change continuously with constant voltage of 3.65V until the current was not more than 3.4<math>\pm</math>0.5A. put aside for 10min</p> <p>b) 室温下, 以 68A 恒流放电至 2.5V; Discharge at 68A to 2.5V at room temperature;</p> <p>c) 重复 a) ~ b), 至容量衰减为额定容量的 80% 止, 所完成的循环次数定义为该电池的循环寿命。 Repeating steps of a) ~ b), until the discharge capacity reached the 80% of rated capacity, the number of cycles completed was defined as the battery cycle life.</p>

## 4.7 安全性能 Safety Characteristics

序号 NO.	项目 Items	技术要求 Technical Requirements	测试方法及步骤 Test Methods & Steps
1	过放电 Over-discharge Test	不爆炸、不起火、不漏液 No explosion. No fire. No leakage.	<p>a) 电池 (组) 标准充电; Standard charge;</p> <p>b) 以 68A 电流放电 90min; Discharge with 68A current for 90min;</p> <p>c) 观察 1h。 Observe for 1h.</p>
2	过充电 Overcharge Test	不爆炸、不起火 No explosion. No fire.	a) 电池 (组) 标准充电 Standard charge;



# 产品规格书 Specification

			<p>b) 以 68A 电流充电至 5.5V, 或充电 1h 后停止充电; Charge to 5.5V with 68A current, or charge for 1h;</p> <p>c) 观察 1h。 Observe for 1h.</p>
3	<p>短路 Short-circuit Test</p>	<p>不爆炸、不起火 No explosion. No fire.</p>	<p>a) 电池(组)标准充电; Standard charge;</p> <p>b) 将电池(组)正、负极经外部短路 10min, 外部线路电阻应小于 5mΩ; Connect the cell(battery module) positive and negative terminals with wire for 10min directly. The resistance of external line should be less than 5mΩ;</p> <p>c) 观察 1h。 Observe for 1h.</p>
4	<p>跌落 Drop Test</p>	<p>不爆炸、不起火、不漏液 No explosion. No fire. No leakage.</p>	<p>a) 电池(组)标准充电; Standard charge;</p> <p>b) 电池(组)正负端子向下从 1.5 米高度处自由跌落到水泥地面上; The cell(battery module) drops with two terminals down from a height of 1.5m onto the cement floor freely;</p> <p>c) 观察 1h。 Observe for 1h.</p>
5	<p>加热 Heating test</p>	<p>不爆炸、不起火 No explosion. No fire.</p>	<p>a) 电池(组)标准充电; Standard charge;</p> <p>b) 电池(组)放入温箱中, 以 5°C/min 速率由室温至 130±2°C, 并保持 30min 后停止加热; Put the cell(battery module) into the incubator, the temperature is up from room temperature to 130±2°C at the speed of 5°C/min, and stop heating after lasting for 30min;</p> <p>c) 观察 1h。 Observe for 1h.</p>
6	<p>挤压 Crushing Test</p>	<p>不爆炸、不起火 No explosion. No fire.</p>	<p>a) 电池(组)标准充电; Standard charge;</p> <p>b) 按下列条件进行试验: According to the following test conditions: ——挤压方向: 垂直于蓄电池极板方向施压; Squeezing direction: Pressure perpendicular to the battery plates;</p>



# 产品规格书 Specification

			<p>——挤压板形式: 半径 75mm 半圆柱体, 半圆柱体的长度大于被挤压电池的尺寸; Squeezing paper shape: half cylinder with 75mm diameter, whose length is more than the size of cell;</p> <p>——挤压速度: (5±1) mm/s; Squeezing speed: (5±1) mm/s;</p> <p>——挤压程度: 电压达到 0V 或变形量达到 30% 或挤压力达到 200KN 后停止挤压, 保持 10min; Squeezing level: Until the battery voltage becomes 0V or the deformation is to 30% or the press is to 200KN, stop squeezing;</p> <p>c) 观察 1h。 Observe for 1h.</p>
7	针刺 Nail penetration Test	不爆炸、不起火 No explosion. No fire.	<p>a) 电池标准充电; Standard charge;</p> <p>b) 用 <math>\Phi 5\text{mm} \sim \Phi 8\text{mm}</math> 的耐高温钢针(针尖的圆锥角度为 <math>45^\circ \sim 60^\circ</math>, 针的表面光洁、无锈蚀、氧化层及油污, 以 <math>25 \pm 5\text{mm/s}</math> 的速度, 从垂直于蓄电池极板的方向贯穿, 贯穿位置宜靠近所刺面的几何中心, 钢针停留在蓄电池中; Penetrate the battery from the vertical direction throughout the inside plates with the <math>\phi 5\text{mm} \sim \phi 8\text{mm}</math> heat resistant needle( the cone angle of the needlepoint is <math>45^\circ \sim 60^\circ</math>, the surface of the needle should be bright and clean, with no rustiness, oxide coating and greasy dirt) at the speed of <math>(25 \pm 5)\text{mm/s}</math> (the needle should stay in the battery);</p> <p>c) 观察 1h。 Observe for 1h.</p>
8	海水浸泡 Seawater immersing test	不爆炸、不起火、不漏液 No explosion. No fire. No leakage.	<p>a) 电池(组)标准充电; Standard charge;</p> <p>b) 电池(组)完全没入 3.5% NaCl 溶液(质量分数)中 2h; 水深应完全没过单体蓄电池。 The cell(battery module) is submerged into 3.5(wt)% NaCl solution for 2h entirely.</p>
9	温度循环 Temperature cycling test	不爆炸、不起火 No explosion. No fire.	<p>a) 电池(组)标准充电; Standard charge;</p> <p>b) 将电池(组)放入温度箱内, 温度箱温度按照表 1 进行调节, 循环次数 5 次;</p>





			Put the cell(battery module) into the incubator, the temperature adjust according to table 1, repeating 5 times, and observing for 1h; c) 观察 1h。 Observe for 1h.
10	低气压 Low air pressure test	不爆炸、不起火 No explosion. No fire.	a) 电池(组)标准充电; Standard charge; b) 电池(组)放入低气压箱内, 调节试验箱中气压为 11.6 kPa, 温度为室温, 静置 6 h; Put the cell (battery module) into the low air pressure box, and set air pressure at 11.6 kPa, laying for 6h at room temperature; c) 观察 1h。 Observe for 1h.

注: 1、电池组以五支或以上单体电池串联;

2、电池安全试验参考 GB/T 31485-2015 《电动汽车用动力蓄电池安全要求及试验方法》。

Notes: 1、The battery module contains five or more cells in series.

2、 Refer to GB/T 31485-2015 *power battery safety require and test methods for electric vehicles* .

表1 温度循环试验一个循环的温度和时间  
Table 1 temperature and time of one temperature cycle test

温度/°C temperature/°C	时间/min time/min	累计时间/min Adding time/min	温度变化率°C/min Temperature change rate °C/min
25	0	0	0
-40	60	60	13/12
-40	90	150	0
25	60	210	13/12
85	90	300	2/3
85	110	410	0
25	70	480	6/7

## 5. 运输注意事项 Precautions for Transportation

电池应在 30%~60%荷电状态下包装成箱进行运输, 在运输过程中应防止剧烈振动、冲击或挤压、防止日晒雨淋, 不得倒置。适用于汽车、火车、轮船等交通工具运输。航空运输请参照 MH/T 1020-2013 《锂电池航空运输规范》。

The batteries should be packed in boxes for transportation which should be conducted not less than 30% SOC. They are also should be prevented from vibration, shock, extrusion, sun-scorched and rain-drenched. It could be delivered by car, train, boat, etc. If it will be delivered by air, please refer to MH/T 1020-2013 *Standards for transport of lithium*



batteries by air.

## 6. 贮存注意事项 Precautions for Storage

电池贮存（超过 1 个月）在环境温度为-20℃~35℃的清洁、干燥通风的室内，避免与腐蚀性物质接触，远离火源及热源。在存放过程中，禁止将电池倒置，并避免机械冲击和重压。

The batteries should be stored (more than 1 month) in a clear, dry and ventilated room under ambient temperature of -20℃~25℃, and it should be kept away from caustic material, combustion source and heat source. Do not turn over battery during storage; mechanical shock and stress should be avoided.

长期不用时，每六个月对电池进行一次标准充放电维护，电池在 30% 荷电状态（电压范围：3.275V~3.305V）下贮存。

If the batteries kept unused for a long time, it should be charged and discharged at the standard model every six months. Store the battery in the state of 30% SOC (voltage scope: 3.275V~3.305V).

电池储存温湿度具体要求如下：

The requirements of storage temperature and humidity are as follows:

1	贮存温度 Storage Temperature	标准储存温度 Standard Storage Temperature	-20℃ ~ 35℃	短期（1个月内） Short term (within 1 month)
		绝对储存温度 Absolute Storage Temperature	-20℃ ~ 45℃	
2	储存湿度 Storage Humidity		<70% RH	

## 7. 充电注意事项 Precautions for Charging

### 7.1 充电电流 Charging Current

充电电流不得超过本规格书中规定的允许最大充电电流。使用高于推荐值电流充电将可能引起电池的充放电性能、机械性能和安全性能的问题，并可能会导致发热或漏液。

The charging current should not be higher than the maximum value described in this specification. If the current is higher than the recommended one, it could bring about a series of problems, such as charging and discharging performance, mechanical property and safety, or even leads to overheat and leakage.

### 7.2 充电电压 Charging Voltage

充电电压不得超过本规格书中规定的绝对充电电压。电池电压高于绝对充电电压值时，将可能引起电池的充



放电性能、机械性能和安全性能的问题，并可能会导致发热或漏液。

The charging voltage should not be higher than the maximum value described in this specification. If the voltage is higher than the maximum value, it could bring about a series of problems, such as charging and discharging performance, mechanical property and safety, or even leads to overheat and leakage.

### 7.3 充电温度 Charging Temperature

电池必须在绝对充电温度：-5℃~55℃的范围内进行充电(详见技术参数表)。

The battery should be charged under the absolute charging temperature of -5℃~55℃ (As shown in the technical parameters table).

### 7.4 禁止反向充电 Reversal charging

正确连接电池的正负极，严禁反向充电。若电池正负极接反，将导致电池报废并产生安全隐患。

Properly connect the terminals of positive and negative of the batteries. The reversal charging is forbidden. If the polarity is reversed, the battery will be damaged and safety problem may occur.

## 8. 放电注意事项 Precautions for Discharging

### 8.1 放电电流 Discharging Current

放电电流不得超过本规格书规定的最大放电电流，大电流放电会导致电池容量快速衰减并可能导致过热，甚至会出现电池冒烟并喷出黑色物质等极端情况。

The discharging current should not be higher than the maximum value described in this specification. Discharging with a higher current may result in the capacity fade and over-heat, even smoke or black material ejected from the case.

### 8.2 放电温度 Discharging Temperature

电池必须在绝对放电温度：-30℃~55℃的范围内进行放电(详见技术参数表)。

The battery should be discharged under the absolute discharging temperature of -30℃~55℃ (As shown in the Technical Parameters table).

### 8.3 禁止过放电 Over discharging

在电池正常使用过程中，应安装电池管理系统防止电池过放电的发生，若电池过放电，将导致电池报废并产生安全隐患。

During normal usage, the battery management system should be applied to avoid over discharging. Once over discharging happens, the battery will be damaged or safety problem may occur.



需要注意的是，在电池长期未使用期间，它可能会由于其自放电特性而处于某种过放电状态。为防止过放电的发生，电池应定期充电，让电池处于 10%~30% 荷电状态。

What should be paid attention to is that the battery can be in the state of over discharging because of self-discharging during the long time storage. To avoid over discharging, the battery should be charged according to a fixed schedule, keep the battery within the 10%~30% SOC.

## 9. 电池操作注意事项 Cautions of Battery Operation

9.1 使用电池前，请仔细阅读本规格书和注意电池表面标识。

Please read the instructions carefully and pay attention to the marks on the surface of battery before use.

9.2 在使用过程中，应远离热源、火源，切勿摔打电池，禁止坠落、冲击电池。

During operation, please keep the cell away from heat source, fire source. Never beat, drop or shock the cell.

9.3 禁止直接焊接电池和用钉子或其它利器刺穿电池。

Do not directly solder the cell or pierce it with a nail or other sharp object.

9.4 禁止将电池倒置，并避免敲击、抛掷、踩踏和弯折电池等。

Do not turn over battery. Keep it from strike, throw, tread or bending.

9.5 禁止短路电池，以免发生危险，电池严重损坏。

Do not make battery short-circuited, in order to avoid from danger incurring or battery damage.

9.6 废弃电池请安全妥当处理，不要投入火中或水中。

Discarded battery should be well disposed. Do not throw it into the fire or water.

9.7 本电池只能使用锂离子电池专用充电器充电。

This battery only can be used with the specified charger for lithium-ion battery.

### 9.8 电池箱设计注意事项

#### Precautions for the Design of Battery Box

- 电池箱应有足够的机械强度以保证其内部电池免受机械撞击；  
Battery box should have enough mechanical strength to make sure that the battery inside would avoid mechanical shock;
- 电池箱内安装电池的部位不应有锋利的边角；



Places inside of the box which are used to fix batteries should not have sharp edges;

- 电池箱的设计应充分考虑单体电池的散热问题，由于电池箱散热设计问题导致的电芯或电池过热损坏，中航锂电不承担质量保证责任；  
The cooling issue of the battery box should be fully considered. Overheating damages to cells or batteries caused by battery box thermal design problem, CALB will not assume responsibility for such quality assurance;
- 电池箱设计中应充分考虑电池的防水、防尘问题，电池箱必须满足国家有关标准规定的防水、防尘等级。由于防水、防尘问题而导致的电芯或电池的损坏（如腐蚀、生锈等），中航锂电不承担质量保证责任。  
Battery box design should be full considered about the battery waterproof and dustproof problem, battery box must meet the relevant national standards for water and dust levels. Cell or battery damage due to water, dust problems caused (such as corrosion, rust, etc.), CALB will not assume responsibility for such quality assurance.

## 9.9 电池的连接 Connection of the Cells

- 使用前应用清理极柱和连接片，确保金属表面没有氧化层，否则可能会导致接触不良，功能失效。  
Rub the terminals and bus bar with sandpaper before usage to make sure that there isn't oxide layer; otherwise poor contact may incur which may leads to improper function.
- 建议使用铝连接带来连接电池。电池在 1C 放电电流时，导电条与极柱之间的保证压降 $<3\text{mV}$ ，可保障不因连接电阻过大导致的异常发热。  
Aluminum material is suggested to connect the terminals. When the battery was discharged at 1c, the voltage between the terminals and bus bar should not reduce more than 3mV, It ensured that exceptional heat did not occur to the battery because of the augment of contacting resistance.
- 采用激光焊接机进行连接操作。  
Laser-beam welding machine is used to connect terminals.

## 9.10 电池管理系统的应用 Applications of Battery Management System (BMS)

客户应配置电池管理系统，严密监控、管理与保护每个电池。

Customers should configure a BMS which is used for strictly monitoring, management and protection.

- 客户应具有电池管理系统详细的设计方案，并对系统特点、框架，系统数据、格式等相关信息进行评估，建立电池管理档案。  
Customers should have a detailed design of BMS, assess system features, frameworks, system data, format and



other related information, and establish battery management file.

- 客户不可擅自修改或者改变电池管理系统的设计和框架，以免影响电池的使用性能。  
The design or framework of BMS must be changed with permission, so as not to affect the performance of battery.
- 客户应保存完整的电池运转的监测数据，用作产品质量责任划分的参考。不具备完整的电池系统使用期限内的监测数据的，中航锂电不承担产品质量保证责任。  
Customers should keep a complete battery operation monitoring data as the reference of responsibility division for product quality. Without complete battery operation monitoring data within system usage period, CALB will not assume responsibility for such quality assurance.
- 避免电池达到过放状态。电池电压低于 2.0V 时，电池内部可能会遭到永久性的破坏，此时中航锂电的产品质量保证责任失效。当放电截止电压低于 2.5V 时，系统内部能耗降低到最小，并在重新充电之前延长休眠时间。客户需要培训使用者在最短的时间内重新充电，防止电池进入过放状态。  
Avoid over-discharge state. When the battery voltage is lower than 2.0V, the internal battery may suffer permanent damage, now the quality assurance responsibilities of the product of CALB failure. When the discharge cut-off voltage is lower than 2.5V, the energy consumption in the internal system minimize and prolong sleep time before recharging. Customers need to train users to re-charge in the shortest time, to prevent the battery into the over-discharge state.
- 电池避免在本规格书禁止的低温条件下充电（包括标准充电，快充，紧急情况充电和再生充电），否则可能出现意外的容量降低现象。电池管理系统应依照最小的充电和再生充电温度进行控制。禁止在低于本规格书规定的温度条件下充电，否则中航锂电不承担质量保证责任。  
Charging at low temperature is forbidden in this specification (including standard charge, fast charge, emergency charge and regenerative charge), or it may reduce the capacity. Battery management system should ensure the cell operating according to the temperature protocol (refer to section 4.2 and 4.3); otherwise the CALB does not assume responsibility for quality assurance.

9.11 维护保养请参见《中航锂电锂离子动力电池安装操作和使用保养手册》

Refer to *CALB Lithium-ion Battery Installation and Maintenance Manual* for maintenance.

## 10. 紧急情况处理 Emergency Treatment

- 如果电池发生泄露，电解液进入眼睛，请不要揉擦，应用清水冲洗眼睛，并立即送医治疗，否则会伤害眼睛；



If the leakage of electrolyte happens, and the electrolyte enters into eyes, rinsing them out with clear water and get a treatment in the hospital immediately instead of rubbing eyes, or the eyes may get hurt;

- 如果电池使用以及贮存过程中发出异味、发热、变色、变形等异常，应立即切断电源，若电池表面温度较高，待电池冷却后，将电池从装置或充电器中移离；

During the usage and storage process, if any peculiar smell, heat, color changing and deformation or any other abnormal occur to the battery, please cut off the power immediately. If the cell surface has got high temperature, please remove it from the device or charger after it gets cool;

- 电池在极端条件下不会发生爆炸，但可能会有冒烟现象发生，遇到该情况可采取将电池隔绝空气的措施，如掩盖沙土，或使用二氧化碳灭火器、干粉灭火器，切忌用水，待烟雾散去后再进行处理。

Explosion will not occur under extreme conditions, but the battery may smoke, for this situation the cell should be isolated from air by any measures except using water, such as covering with sand, or using carbon dioxide fire extinguisher, dry powder fire extinguisher. The cell should be treated after smoke dispersing.

## 11. 其它事项 Others

任何本规格书中未提及的事项，请咨询本公司。当本规格书版本更新时，本公司不做另行通知。

If there are any items not mentioned in this specification, please contact our company. When the version of the specification is updated, the Company will not issue a separate notice.