



B-TEC

LITHIUM

Owner's Manual

- EPL-100BT-12V-SLIM • EPL-125BT-12V-G2 • EPL-200BT-12V-G2
- EPL-300BT-12V-G2 • EPL-100BT-24V • EPL-150BT-24V-G2 • EPL-100BT-36V

**Enerdrive B-TEC Lithium (LiFePO₄), Lithium Ion Phosphate
Prismatic Cell Battery with Smart Phone Monitoring**

B-TEC LITHIUM

For safe and optimum performance, the Enerdrive ePOWER B-TEC LiFePO4 Lithium Ion Phosphate Battery with Smart Phone Monitoring must be used properly. Carefully read and follow all instructions and guidelines in this manual and give special attention to the CAUTION and WARNING statements.

PLEASE KEEP THIS MANUAL FOR FUTURE REFERENCE

Disclaimer

While every precaution has been taken to ensure the accuracy of the contents of this guide, Enerdrive assumes no responsibility for errors or omissions. Note as well that specifications and product functionality may change without notice.

Important

Please be sure to read and save the entire manual before using your Enerdrive ePOWER B-TEC LiFePO4 Lithium Ion Phosphate Battery with Smart Phone Monitoring. Misuse may result in damage to the battery, and/or cause harm or serious injury. Read manual in its entirety before using the unit and save manual for future reference.

Product Number

EPL-100BT-12V-SLIM
EPL-125BT-12V-G2
EPL-200BT-12V-G2
EPL-300BT-12V-G2
EPL-100BT-24V
EPL-150BT-24V-G2
EPL-100BT-36V

Document Part Number

Enerdrive B-TEC G2 Manual (Rev. 3.1)
2021

Support Contact Information

Dometic Power & Control (Enerdrive) Pty Ltd
P.O. Box 9159, Wynnum Plaza, Queensland, Australia 4178
Ph: 1300 851 535 Fax: 07 3390 6911
Warranty Returns: Reply Paid 8786, Wynnum Plaza, QLD 4178
Email: support@enerdrive.com.au
www.enerdrive.com.au

TABLE OF CONTENTS

SECTION 1 - INSTALLATION	4
SECTION 2 - CONNECTIONS	4
SECTION 3 - CHARGING	5
SECTION 4 - DISCHARGING (USING THE BATTERY)	6
SECTION 5 - PROTECTING YOUR BATTERY	7
SECTION 6 - RESTARTING YOUR BATTERY	8
SECTION 7 - USING THE SMART PHONE BATTERY MONITOR APP	9
SECTION 8 - WARNINGS	10
SECTION 9 - FAQ	11
SECTION 10 - BATTERY SPECIFICATIONS	13
SECTION 11 - DIMENSIONS	15
SECTION 12 - WARRANTY	22

Section 1 - Installation

Your B-TEC battery must be installed in a dry and cool location.

Supplied battery trays and straps are the preferred mounting method. Ensure that sufficiently rated fasteners are used to hold the tray firmly to the mounting material.

Enerdrive highly recommend the battery is installed in the upright position.

Enerdrive approve installation of B-TEC batteries in accommodation areas of RV's. Temperatures must not exceed the rated operating temperatures therefore natural, or fan forced ventilation maybe required.

There should be 25mm clear space around the B-TEC battery.

Consideration should be taken to not mount the battery near any metallic service lines such as LPG, diesel, or petrol lines. This is to ensure no accidental shorting of the battery terminals occur, especially when fitting or removing the battery.

B-TEC batteries must not be installed -

- In vehicle engine bays or in high heat environments, refer to Section 10 - Battery Specifications
- In wet areas such as caravan chassis mounts, open ute trays or boat deck areas.
- Inside compartments dedicated to carrying gas.

Section 2 - Connection

It is recommended that no more than four terminals be connected to a battery terminal, if you do have more than 4 terminals the use of a fuse block and negative busbar are recommended.

Cable terminal should be in the order with heaviest current draw (largest cable) in contact with the battery to light est. current draw (smallest cable) terminals on the top.

Use of insulating terminal boots is recommended, especially in areas where accidental shorting may occur, such as storage lockers or under lounges and beds. Connect the Positive (Red) and Negative (Black) cables to the battery, ensuring you are using cable that is of adequate size for the demands of the system, and well crimped and protected termination lugs.

Example;

1000W Inverter - at least Guage 2 (35mm²)

2000W Inverter - at least Guage 00 (70mm²)

3000W Inverter - at least Guage 000 (95mm²)

Cable Conversion Guide

Standard	Unit												
AWG	0000	000	00	0	1	2	4	6	8	10	12	14	16
Diameter (mm)	11.68	10.40	9.27	8.25	7.35	6.54	5.19	4.11	3.26	2.59	2.05	1.63	1.29
Cross Section (mm ²)	107.1	84.9	67.5	53.5	42.4	33.6	21.2	13.3	8.4	5.3	3.3	2.1	1.3

The spring washers must be used on the battery terminal bolts - they apply pressure to the lugs for a secure connection. There is no need to over-tighten the bolts, simply ensure there is no movement of the cables. Make sure the main Battery Cable lug is mounted directly onto the Battery terminal with no washers between them.

Section 3 - Charging

Lithium batteries need to be charged slightly different to other batteries.

To ensure they live a long life and provide maximum capacity, you must use a charger with a lithium LiFeP04 setting - this includes:

- AC Chargers
- DC to DC Chargers
- Solar Controllers

If your charger allows, set the charge voltage from 14.2 - 14.6 Volts and Float 13.5 - 13.6 Volts and proceed with charging. We recommend charging at the lower end of the voltage scale for maximum longevity of the battery.

It is recommended that the charging current should be 30% of your battery capacity. You can charge at higher currents but 30% is the recommended for long life.

See **Section 10 - Battery Specifications**.

***Note:**

You can charge a lithium battery with a non-lithium charger, but these chargers can deliver too much or too little voltage and may not cut off when the battery is full.

DO NOT use a charger with a "Pulse Stage" or "Equalisation Mode". This will damage the battery and void warranty.

DO NOT connect this battery to a start battery with a VSR (Dual Battery System or "Voltage Sensitive Relay"). The voltage of the Lithium battery may keep the VSR switched on resulting in it discharging into the start battery, and/or flattening the start battery.

DO NOT charge B-TEC batteries direct from an alternator.

Section 4 - Discharging (using the battery)

The Enerdrive B-TEC Lithium Battery can deliver a very high discharge current due to the high power, high quality Battery Management System (BMS) and prismatic Lithium cells inside the battery. Refer to Section 10 - Battery Specifications for the maximum rated discharge current of your battery.

For this to happen, you **MUST USE** cable of the correct guage.

Inverter Usage

It is recommended to not put more load on your batteries than the rating of the BMS installed. We also recommend following the below even if you have two batteries in parallel, this protects overloading a single battery if the other battery in the bank was to shut down (i.e. low capacity).

- 12V 100AH B-TEC - 12V 1000W Inverter Max
- 12V 125AH B-TEC - 12V 1000W Inverter Max
- 12V 200AH B-TEC - 12V 2600W Inverter Max
- 12V 300AH B-TEC - 12V 3000W Inverter Max
- 24V 150AH B-TEC - 24V 3500W Inverter Max

Section 5 - Protecting Your Battery

Lithium batteries cannot be protected effectively by monitoring voltage due to their ability to maintain a higher voltage for much longer than AGM or flooded/sealed batteries.

“State of Charge” (SOC%) percentage is the most accurate and effective method of disconnecting loads from the battery - this requires a battery monitor which uses a “shunt” to measure the current going into (Charging) and coming out of (Discharging) the battery.

Example;

200 Amp Battery	Fully Charged	State of Charge = 100%
	50 Amps used	State of Charge = 75%
	100 Amps used	State of Charge = 50%

It is recommended that Lithium batteries not be discharged below 20% State of Charge or the battery life may be shortened.

As an added layer of protection, the Enerdrive B-TEC Lithium Battery also has a built-in low voltage disconnect circuit. If this occurs, please refer to **Section 6 - Restarting Your Battery**.

If your battery has shut down due to low voltage you must charge your battery within 14 days to prevent permanent damage occurring to the cells.

B-TEC LITHIUM

Section 6 - Restarting Your Battery

Batteries with Reset Button on Battery

We strongly recommend keeping the battery charged to avoid activating the internal low battery voltage disconnect.

If your DC system shuts down, the battery may require re-starting. Please use the following procedure:

1. Turn off all DC and AC Loads
2. Connect charging source/s and switch ON
3. Hold the "Reset" button 5 seconds, release and quick press
4. Release and wait 7 seconds
5. Power will be restored and charging will commence after a few seconds
6. When the SOC (State of Charge) is above 20%, loads can be switched on if required



By continuously tripping the low voltage disconnect of the battery you may cause damage to sensitive electronic equipment that is attached to the battery. i.e. battery chargers, solar controllers, inverters, stereo equipment etc - all of which are not covered under the battery warranty.

Batteries without Reset Button on Battery

To reconnect, a charge voltage of $\geq 12.8\text{v}$ must be applied to the battery before the over-discharge release will activate and allow charge current to flow into the battery. This can be done via a momentary reset switch between the start battery and B-TEC or by jump starting with a portable power pack.

Follow the above steps to turn off all DC and AC loads, turn on charging sources and then activate reset switch or apply jump start pack, disconnect as soon as chargers begin charging.

Section 7 - Using the Smart Phone Battery Monitor App

The Enerdrive B-TEC Lithium Battery incorporates a wireless Smart Phone Monitoring system. By downloading the Android™ or Apple® app to your Smart Phone or tablet device, you can monitor the following information;

- Battery Capacity
- Battery Voltage
- Battery Current (Amps)
- Battery State of Charge (SOC)
- Battery State of Health (SOH)
- Battery Status
- Individual Cell Voltage
- Battery Temperature
- Battery Cycles
- Battery Alarms
- Battery Notifications

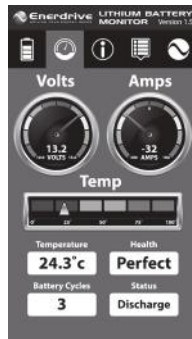
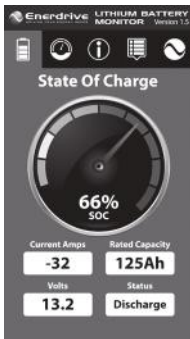

Alarms Definitions

HV - High Voltage

LV - Low Voltage

OCC - Over Current Charge

OCD - Over Current Discharge

LTD - Low Temperature Discharge

LTC - Low Temperature Charge

HTD - High Temperature Discharge

HTC - High Temperature Charge

(Refer to Section 10 - Battery Specifications for values).

* The red warning light is only an indicator, not a fault condition.

* The 3 vertical dots on the lower part of the main screen allows you to change the Bluetooth name of the battery. Touch the dots, and use 1234 as the password to enter your battery name.

* A notification will only appear in the notifications page if under alarm condition.

Section 8 - Warnings

Please read and follow the cautions listed on the battery before installation. Improper use may cause heat, fire, rupture, damage or capacity deterioration of the battery. Dometic Power & Control (Enerdrive) Pty Ltd is not responsible for any accidents caused by the usage without following our specification.



WARNING!

Failure to follow these instructions may result in early battery failure or possible personal injury.

- Do not use the battery for cranking/starting applications.
- Do not series connect the battery.
- Do not dispose of in fire.
- The battery must be installed far away from heat sources, high voltage, and avoid exposed sunlight for long periods of time.
- Do not throw the battery into water.
- Do not connect the positive and negative terminals of battery together.
- Do not ship or store battery together with metal.
- Do not disassemble the battery. Battery warranty will be voided if the case is opened.
- Do not drop, impact or puncture the battery.
- Do not allow the battery to sit in a discharged state $\leq 11.50V$
- When the battery capacity is low ($\leq 15\%$ SOC), please charge the battery.
- Please use the matched or suggested charger that contains a Lithium charge profile for this battery. Failure to install the correct battery charger will void all warranty.
- If the battery emits a peculiar smell, heating, distortion or appears to have any abnormality during operation or storage, please stop using the battery and take it out of service. Contact Enerdrive for further details
- If the battery leaks and gets into eyes or on skin, do not wipe. Rinse with clean water and seek medical attention immediately.

Low Battery Voltage Disconnect

The battery has a low voltage disconnect incorporated for self-protection. If the battery is drawn down to the internal low voltage disconnect set point 2.8v per cell (11.2V for 12V battery) the battery will disconnect.

Section 9 - FAQ

Q: Can I parallel B-TEC batteries?

A: The short answer is yes.

The long answer is - if you are drawing large currents, the maximum current delivered will be limited to the maximum instantaneous discharge capacity of one battery, for example; 200A on a 200Ah G2 B-TEC Battery.

With low to medium current draw installations (the vast majority of applications) you may never see an issue and your storage capacity will be greatly increased - I.E. 2 x 200 Amp = 400 Amp capacity.

When installing, fully charge the batteries separately - then let sit for 30 minutes before connecting together. When connecting in parallel - take the positive from Battery 1, and the negative from Battery 2 to your system as per the diagram below.

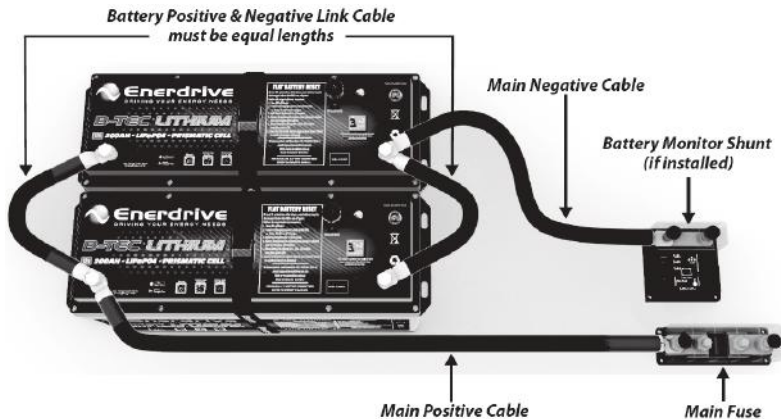

The Smart Phone App will only show the information from one battery at a time - not both. This is another advantage of a separate Battery Monitor - it will show the total system environment.

***Note:** Slight variance of State of Charge or Amps may occur between the batteries in parallel however these should not vary by more than 5%.

It is recommend that annually the batteries be disconnected and individually charged allowing them to sit at a fully charged state for 12hrs each before connecting back together.

B-TEC LITHIUM

Q: Can I series connect B-TEC batteries to achieve higher voltage?

A: No. Enerdrive offers higher voltage Lithium solutions - contact us for details.

Q: Can I use an Inverter with my B-TEC battery?

A: Yes. Refer to Section 4 for more detail.

Q: Can I install the B-TEC battery in a wet area?

A: No. Due to the construction of the B-TEC cases the batteries must be installed in a dry environment to protect against moisture ingress.

Q: Can I install the B-TEC battery on its side or end?

A: No.

Section 10 - Specifications

SPECIFICATIONS: Enerdrive B-TEC 12v-G2 Lithium Battery Technical Data - 12 VOLT								
Normal Specification	EPL-100BT-12V-SLIM	EPL-125BT-12V-G2	EPL-200BT-12V-G2	EPL-300BT-12V-G2				
Nominal Voltage	12.8V							
Nominal Capacity	100Ah	125Ah	200Ah	300Ah				
Cycle Life (DOD - 80% under controlled conditions)	≥2000 Cycles							
Standard Charge Specification (Lithium profile charger required)								
Battery Charge Temperature	0 - 45°C							
Normal Charge Voltage CV/CC*	14.20 ~14.60							
Standby (Float) Voltage	13.50 ~13.80							
Maximum Charge Current	80A @ 25°C for 30mins	80A @ 25°C for 30mins	150A @ 25°C for 30mins	190A @ 25°C for 30mins				
Nominal Charge Current for Maximum Life	20~50A	20~60A	40~100A	80~120A				
Standard Discharge Specification								
Battery Discharge Temperature	-20°C ~ 60°C							
Battery Output Voltage Range	11.0 ~ 14.60V approx.							
Maximum Discharge Current	100A @ 25°C ±5°C for 30 mins	100A @ 25°C ±5°C for 30 mins	200A @ 25°C ±5°C for 30 mins	250A @ 25°C ±5°C for 15 mins				
Pulse Discharge Current	250A for 1.0s	450A for 1.0s						
Discharge Cut-Off Voltage	≤11.20V							
Circuit Protection								
The battery is supplied with a LiFePO4 Battery Management System (BMS) that can monitor and optimise each single prismatic cell during charge & discharge, to protect the battery pack from overcharge, over discharge & short circuit. Overall, the BMS helps to ensure safe and accurate operation of the battery.								
Over-Charge Protection								
Over-Charge Protection Per Cell	3.90 ± 0.03V							
Over-Charge Release Per Cell	3.60 ± 0.05V							
Over-Charge Release Method	Discharge below release voltage							
Over-Discharge Protection								
Over-Discharge Protection Per Cell	2.80V ± 0.05V							
Over-Discharge Release Per Cell	3.20V ± 0.05V							
Over-Discharge Release Method	Apply Charge/Voltage ≥12.8v							
Over Current Protection								
Discharge Over Current	110A for 30s - 450A for 1s	110A for 30s - 450A for 1s	220A for 30s - 450A for 1s	280A for 25s - 400A for 3.5s				
Protection Reset Time	Approx 10s Auto Release							
Over Current Release Method	Disconnect Load							
Over Temperature Protection								
Battery Discharge Over Temp	Protection to 65°C ± 5°C							
	Protection to 50°C ± 5°C							
Battery Charge Over Temp	Protection to 55°C ± 5°C							
	Protection to 45°C ± 5°C							
Short Circuit Protection	Auto release after 5s							
Mechanical Characteristics		Without Tray	Without Tray	With Tray	Without Tray	With Tray	Without Tray	With Tray
Dimensions	Length	551mm	318mm	318mm	505mm	505mm	521mm	521mm
	Width	110mm	165mm	165mm	173mm	173mm	280mm	288mm
	Height	240mm	232mm	240mm	265mm	272mm	253mm	261mm
	Weight	Approx. 12.5kg	Approx. 15.5kg	Approx. 16.2kg	Approx. 25.0kg	Approx. 26.0kg	Approx. 38.2kg	Approx. 39.4kg
Storage Information								
Temperature & Humidity Range	≤30 days - 20°C to 60°C, 5 ~ 75% RH							
	≥90 days - 10°C to 45°C, 5 ~ to 75% RH							
Self-Discharge Rate	≤3% per month							

SPECIFICATIONS: Enerdrive B-TEC Lithium Battery Technical Data - 24 & 36 VOLT

Normal Specification	EPL-100BT-24V	EPL-150BT-24V-G2	EPL-100BT-36V		
Nominal Voltage	25.6V	25.6V	38.4V		
Nominal Capacity	100Ah	150Ah	100Ah		
Cycle Life (DOD - 80% under controlled conditions)	≥2000 Cycles				
Standard Charge Specification (Lithium profile charger required)					
Battery Charge Temperature	0 - 45°C				
Normal Charge Voltage CV/CC*	28.80 ~29.20	28.80 ~29.20	43.20 ~43.80V		
Standby (Float) Voltage	27.00 ~27.60	27.00 ~27.60	40.5 ~41.40V		
Maximum Charge Current	50A @ 25°C for 30mins	100A @ 25°C for 60mins	50A @ 25°C for 30mins		
Recommended Charge Current for Maximum Life	20~50A	30~75A	20~50A		
Standard Discharge Specification					
Battery Discharge Temperature	-20°C ~ 60°C				
Battery Output Voltage Range	22.0 ~ 29.20V	22.0 ~ 29.20V	33.0 ~ 43.80V		
Maximum Discharge Current	100A @ 25°C ±5°C for 30 mins	150A @ 25°C ±5°C for 30 mins	100A @ 25°C ±5°C for 30 mins		
Pulse Discharge Current	450A for 1.0s				
Discharge Cut-Off Voltage	≤22.40V	≤22.40V	≤33.60V		
Circuit Protection					
The battery is supplied with a LiFePO4 Battery Management System (BMS) that can monitor and optimise each single prismatic cell during charge & discharge, to protect the battery pack from overcharge, over discharge & short circuit. Overall, the BMS helps to ensure safe and accurate operation of the battery.					
Over-Charge Protection					
Over-Charge Protection Per Cell	3.90 ± 0.03V				
Over-Charge Release Per Cell	3.60 ± 0.05V				
Over-Charge Release Method	Discharge below release voltage				
Over-Discharge Protection					
Over-Discharge Protection Per Cell	2.80V ± 0.05V				
Over-Discharge Release Per Cell	3.20V ± 0.05V				
Over-Discharge Release Method	Apply Charge/Voltage ≥25.6v	Apply Charge/Voltage ≥25.6v	Apply Charge/Voltage ≥38.4v		
Over Current Protection					
Discharge Over Current	110A for 30s - 450A for 1s	170A for 10s - 400A for 3.5s	110A for 30s - 450A for 1s		
Protection Reset Time	Approx. 30s Auto Release				
Over Current Release Method	Disconnect Load				
Over Temperature Protection					
Battery Discharge Over Temp	Protection to 65°C ± 5°C				
	Protection to 50°C ± 5°C				
Battery Charge Over Temp	Protection to 55°C ± 5°C				
	Protection to 45°C ± 5°C				
Short Circuit Protection	Auto release after 5s				
Mechanical Characteristics		Without Tray	Without Tray	With Tray	Without Tray
Dimensions	Length	446mm	521mm	521mm	520mm
	Width	161mm	280mm	288mm	273mm
	Height	245mm	253mm	261mm	225mm
Weight	Weight	Approx. 25.0kg	Approx. 38.2kg	Approx. 39.4kg	Approx. 37.7kg
Storage Information					
Temperature & Humidity Range	≤30 days - 20°C to 60°C, 5 ~ 75% RH				
	≥90 days - 10°C to 45°C, 5 ~ to 75% RH				
Self-Discharge Rate	≤3% per month				

EPL-100BT-12V-SLIM

DIMENSIONS (NO STRAP & TRAY INCLUDED WITH THIS MODEL)

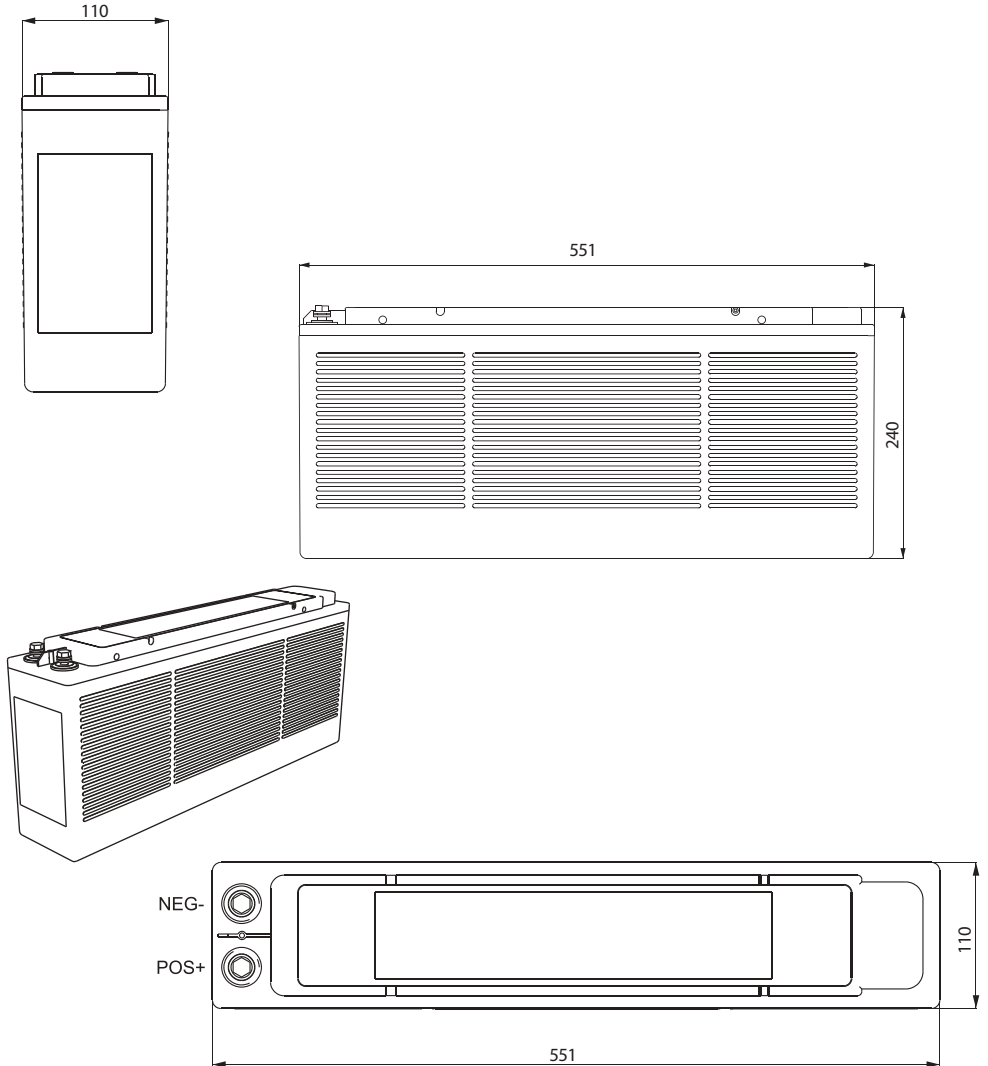

B-TEC LITHIUM

EPL-125BT-12V-G2

DIMENSIONS WITHOUT STRAP & TRAY

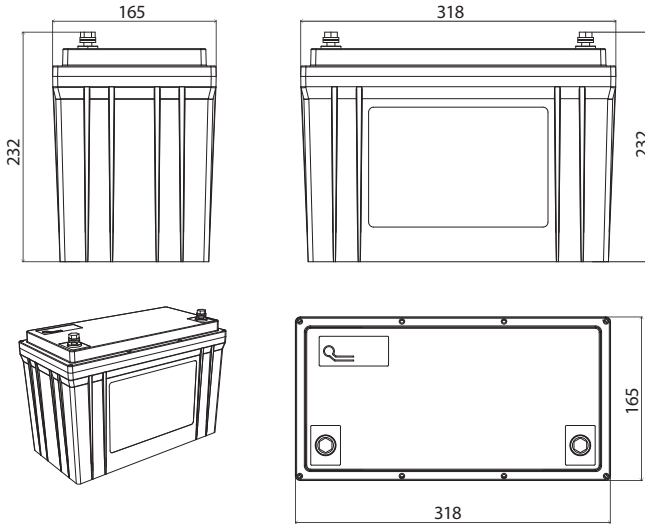

EPL-125BT-12V-G2

DIMENSIONS WITH STRAP & TRAY

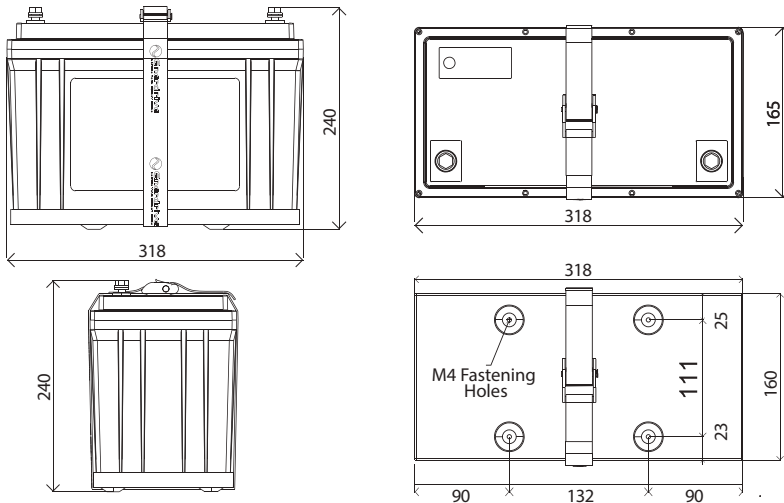

EPL-200BT-12V-G2

DIMENSIONS WITHOUT STRAP & TRAY

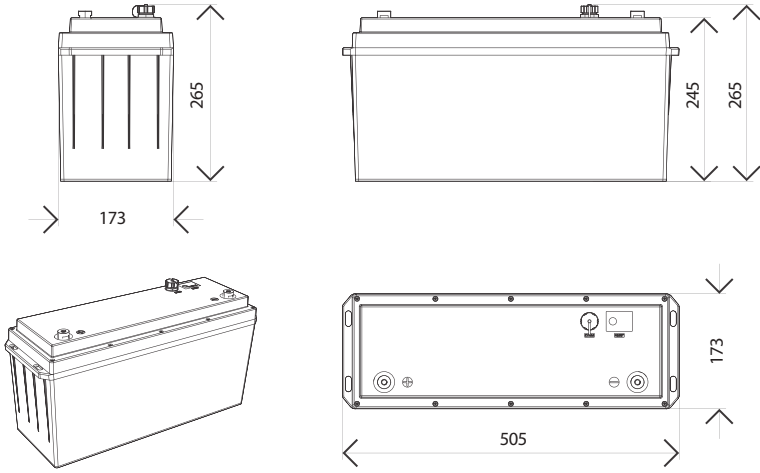

EPL-200BT-12V-G2

DIMENSIONS WITH STRAP & TRAY

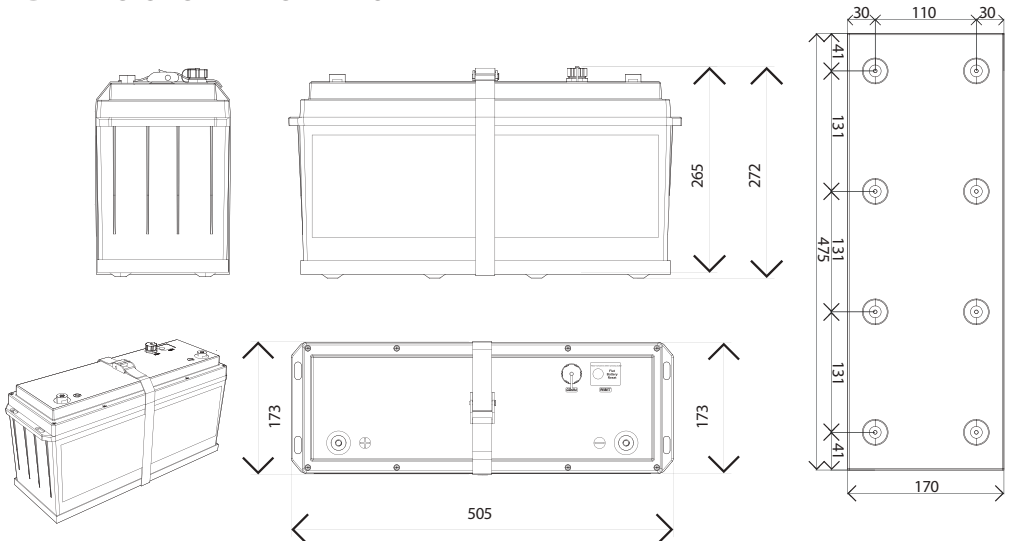

B-TEC LITHIUM

EPL-300BT-12V-G2

DIMENSIONS WITHOUT STRAP & TRAY

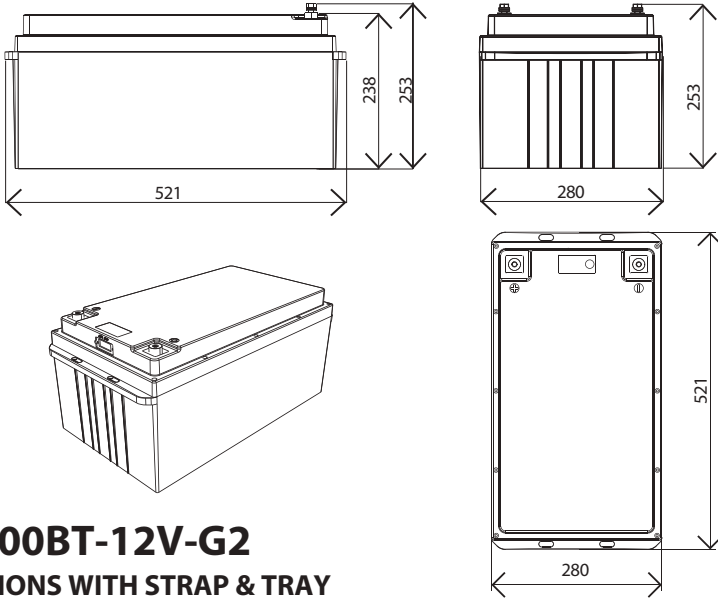

EPL-300BT-12V-G2

DIMENSIONS WITH STRAP & TRAY

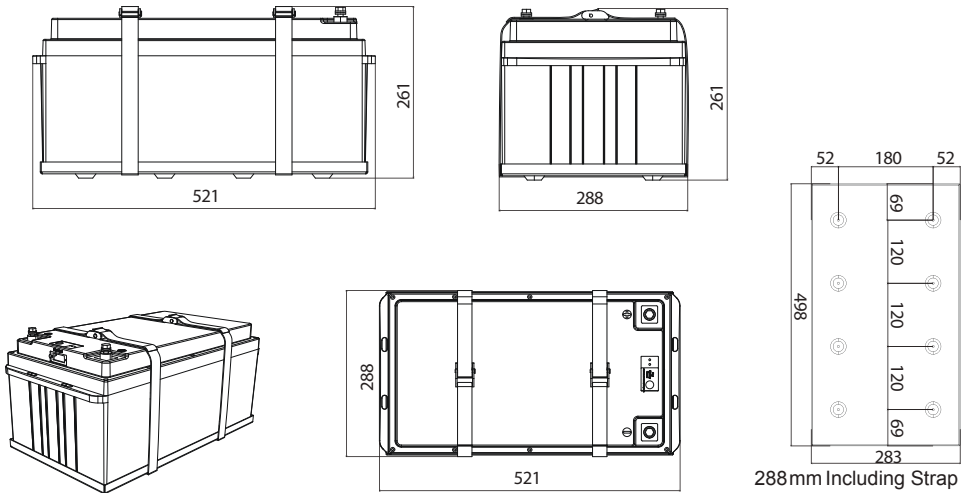

EPL-100BT-24V

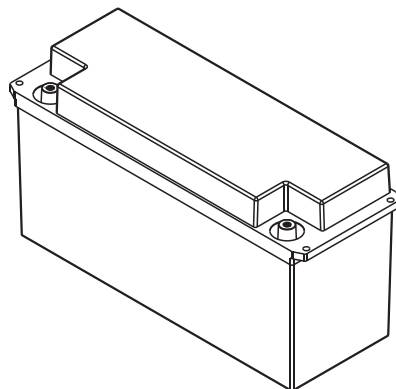
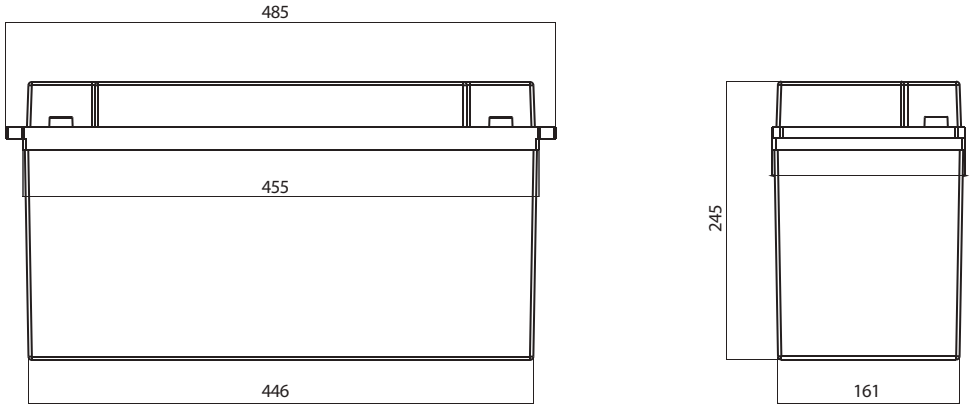

B-TEC LITHIUM

EPL-150BT-24V-G2

DIMENSIONS WITHOUT STRAP & TRAY

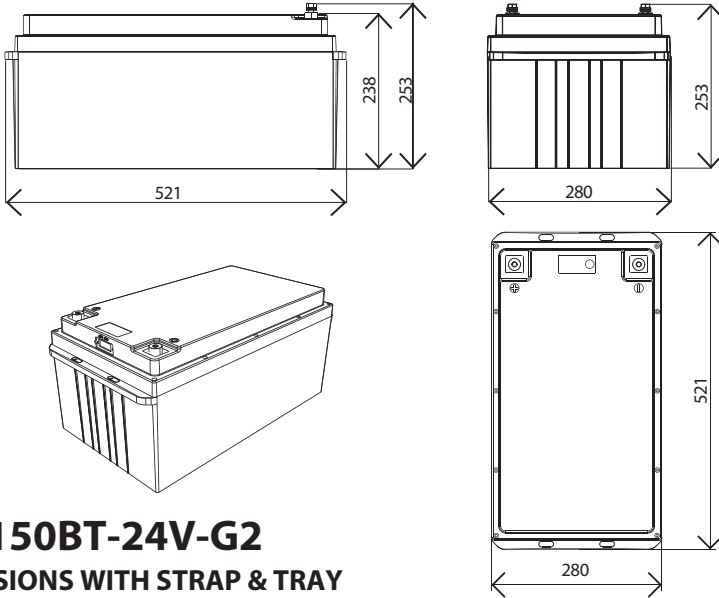

EPL-150BT-24V-G2

DIMENSIONS WITH STRAP & TRAY

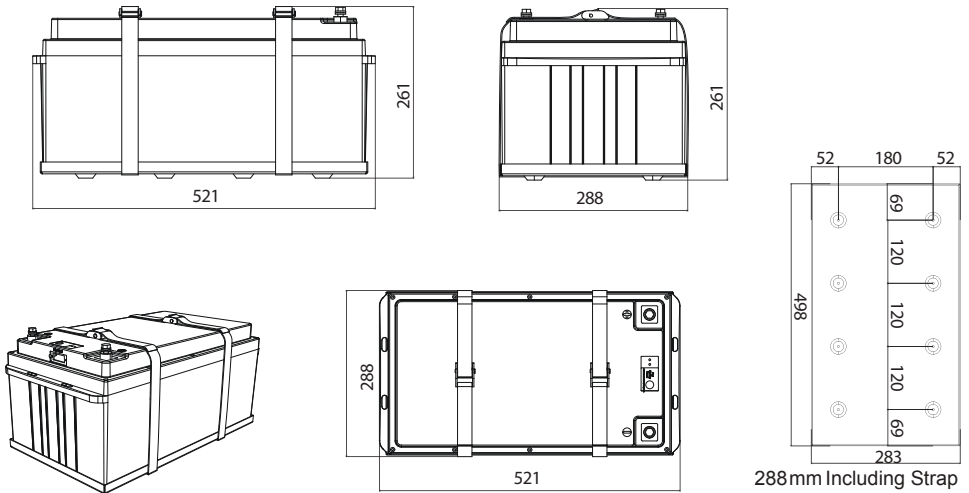

EPL-100BT-36V

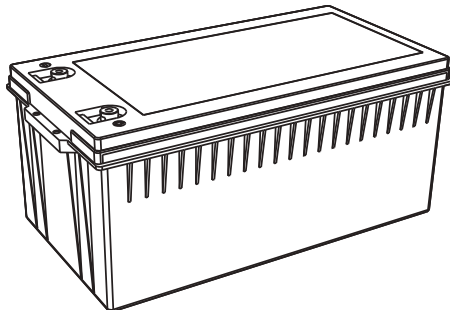
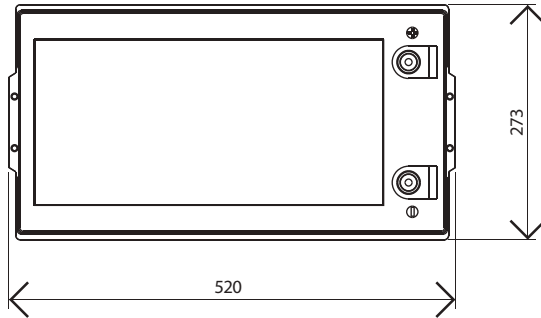
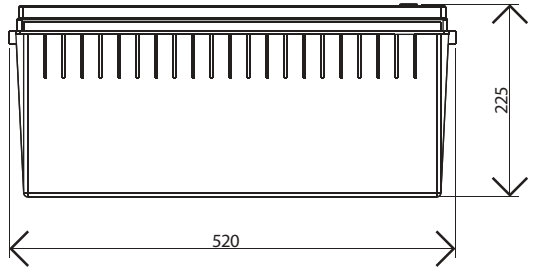
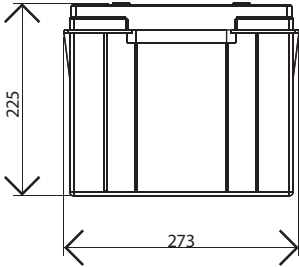

Section 12 - Warranty



5 Year Warranty

In the unlikely event that a technical issue arises with an Dometic Power & Control (Enerdrive) Pty Ltd product, customers are encouraged to initially contact the Enerdrive Support Team on 1300 851 535 or support@enerdrive.com.au for immediate and efficient expertise and first class product support.

Important Note: Consumer Protections

If you have purchased your product in Australia, you should be aware that:

This warranty is provided in addition to other rights and remedies held by a consumer at law. Our goods come with guarantees that cannot be excluded under the Australian Consumer Law. You are entitled to a replacement or refund for a major failure and for compensation for any other reasonably foreseeable loss or damage. You are also entitled to have the goods repaired or replaced if the goods fail to be of acceptable quality and the failure does not amount to a major failure.

Dometic Power & Control (Enerdrive) Pty Ltd warrants that its Products will be free from defects in materials and workmanship (subject to limits, and in normal conditions, as described in the complete Enerdrive Warranty Policy) for up to 5 years from the date of purchase.

For full terms, conditions and claim process, refer to the Enerdrive website.
<https://enerdrive.com.au/warranty/>



Dometic Power & Control (Enerdrive) Pty Ltd

P.O. Box 9159, Wynnum Plaza, Queensland, Australia 4178

Ph: 1300 851 535 / Fax: 07 3390 6911

Email: support@enerdrive.com.au

Web: www.enerdrive.com.au