



Dongguan Daly Electronics Co. Ltd

Product Specifications

Product Model: DL-R32U-F16S0150ATJ-MM00-S4RV

Product Name: LiFePO4 16S 48V150A Common port with Balance, UART, Bluetooth

Version: Rev 1.0 – Modified to Solar 4 RV's Specifications



	DL-R32U-F16S150ATJ-MM00-S4RV		
--	------------------------------	--	--

Product Summary:

- Using foreign premium IC class-A protection.
- Professional, high-current wiring design and workmanship thus can withstand the shock of high current
- Using heat-dissipating glue with a double-sided heat dissipation design, heat is dissipated passively
- Physically shock-resistant, waterproof PCB with many protective functions
- Complete over-charge, over-discharge, over-current, short-circuit, and equalization functions

Electrical Parameters: (Room temperature 25°C, humidity 55%)

(N0)	(Description)	(Specification)	(Unit)	Remarks
1	(Discharge) (Continuous discharge current)	150	A	
2	(Charge) (Charge voltage)	58.4	V	Adjustable
	(Continuous charge current)	150	A	
3	(Over charge protection) (Over charge detect voltage)	3.7±0.05	V	Adjustable
	(over charge protection delay)	1	S	Adjustable



	DL-R32U-F16S150ATJ-MM00-S4RV		
--	------------------------------	--	--

		(over charge release voltage)	3.6±0.05	V	Adjustable
4	(Balance)	(Balance detect Voltage)	3.20	V	Adjustable
		(Balance release voltage)	3.20	V	Adjustable
		(Balance current)	30±5	mA	
5	(Over discharge) protection	(Over discharge detect)	2.6±0.1	V	Adjustable
		(Over discharge detect delay)	1	S	Adjustable
		(Over discharge release voltage)	2.7±0.1	V	Adjustable
6	(Over Charge current protection)	(Overcharge current detect delay)	250±15	A	Adjustable
		(Overcharge current detect delay)	1	S	Adjustable
		(Overcharge current protection release condition)	(Off load)		
7	(Over discharge current protection)	Over discharge current detect	500±100	A	Adjustable
		(Over discharge current detect delay)	1	S	Adjustable
		(Over discharge current protection release condition)	(Off load)		
8	(Short Circuit protection)	(Short Circuit protection condition)	(Short circuit of external load)		
		(Short circuit detect delay)	320	μS	Adjustable
		(Short circuit protection release)	(Off load)		
9	(Temp Protect)	(Charge Temperature protection degrees)	-5~55	°C	Adjustable
		(Discharge Temperature protection degrees)	-30~60	°C	Adjustable



	DL-R32U-F16S150ATJ-MM00-S4RV		
--	------------------------------	--	--

10	(Means of communication)	UART (Adjusting Settings) PC Interface Bluetooth (Status Only) Android and iOS			Play Store/ App Store:  SMART BMS DalyBMS
11	(Inner Resistance)	(Main Circuit Conduct Inner resistance)	<20	mΩ	
12	Self Consumption	(Working current)	15	mA	
		Sleep current (over-discharge)	600	uA	
13	(Working Temp)	(Temp range)	-20~70	°C	
13	(Storing Temp)	(Temp range)	-40~80	°C	

(BMS wiring Connection)

(1) (Product picture)

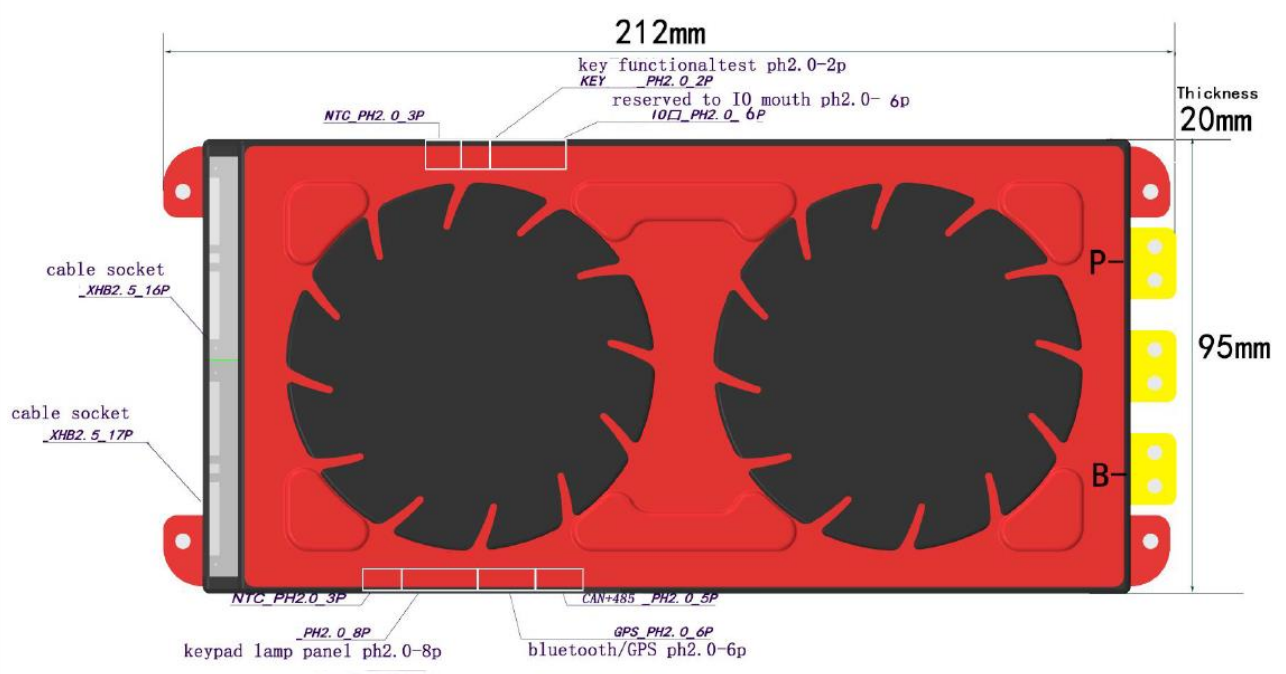

(Interface definition)

(GROUP)	(NAME)	(PIN)	(DESCRIPTION)
Battery acquisition equalizer interface	B00	1	Battery Total Negative
	B01	2	Battery positive electrode 1
	B02	3	Battery positive electrode 2

	B14	15	Battery positive electrode 14
	B15	16	Battery positive electrode 15
	B16	17	Battery positive electrode 16
Bluetooth / GPS module interface	GND	1	GND
	POW_3.3V	2	Bluetooth module power supply 3.3 V
	15V	3	Power supply 15 V GPS module
	BLU_DRV	4	GPS control of power outages/recovery
	URAT_TX 2	5	Bluetooth communication Transmitter
	URAT_RX 2	6	Bluetooth communication Receiver
Key switch	TRIG+	1	Activate input pin
	TRIG-	2	Activate output pin
External power indicator panel port	GND	1	GND
	POW_3.3V	2	3.3 V of lamp board power supply
	S1	3	Keyboard
	LED_51	4	Fifth lamp (100%)
	LED_41	5	Fourth lamp (80%)
	LED_31	6	Third lamp (60%)



	DL-R32U-F16S150ATJ-MM00-S4RV		
--	------------------------------	--	--

	LED_21	7	Second Lamp (40%)	
	LED_11	8	First Lamp (20%)	
Temperature sensor input port	NTC1	1	Temperature Line #1	
	GND	2	GND	
	NTC2	3	Temperature Line #2	
Temperature sensor input port	NTC5	1	Temperature Line #3	
	GND	2	GND	
	NTC4	3	Temperature Line #4	
485 / CAN communication interface	UART_RX 1	1	485 Communication receiver	
	UART_TX 1	2	485 Communication transmitter	
	GND	3	GND	
	CAN_H	4	CAN communication high	
	CAN_L	5	CAN communication low	
Reserved IO interface	AI1	1	Switching signal	
	AI2	2	Switching signal	
	DI1	3	Switching signal	
	DO1	4	Switching signal	
	VCC_EX	5	External power supply	
	GND_EX	6	External power supply	

(2) (Wiring diagram)

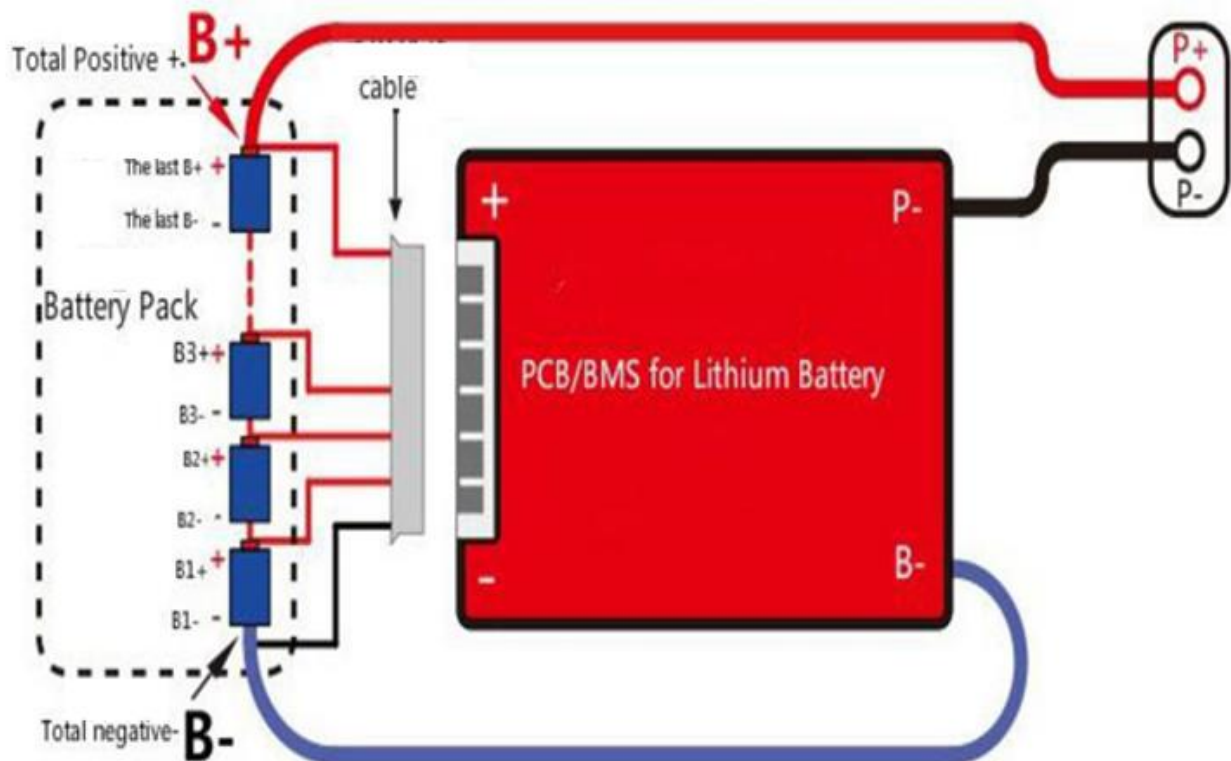

(3) (Wiring operation)

(1) First connect the large (B-) cable of the protection board to the total negative pole of the battery pack

(2) Then connect the small balance cables starting from the black cable connected to B-, the next red cable connects the positive pole of the first string of batteries, and the next string is connected in turn. Once all connected, TEST to ensure the voltages are correct otherwise the unit will be destroyed and warranty void if cables are not wired in the correct order!

(3) Connect to a power supply / charger between P- and the battery Positive to power the unit on. The Bluetooth and MOSFETs will not activate until this step is completed.

Removal: When removing the protection board, first pull out the small balance cables, then remove Power cable B-.



	DL-R32U-F16S150ATJ-MM00-S4RV		
--	------------------------------	--	--

(Warranty)

We guarantee a 3-year product warranty, if the damage is caused by improper operation, we will conduct the repair with charge. The warranty does not cover shipping costs, the cost of shipping both to and from the user must be paid for by the user.

(Additional Information)

1. Lithium battery BMS units with different voltage ranges cannot be mixed. i.e. The LiFePO4 BMS cannot be used for LiPo batteries.
2. Daly uses high quality cables, do not replace the Daly provided cables with any other cables.
3. When testing, installing, or contacting the protective board, take measures to avoid static electricity.
4. Do not let the heat dissipation surface of the protection board directly contact the battery core, otherwise the heat will be transmitted to the battery core, which will affect the safety of the battery.
5. Do not disassemble or change the components of the protection board.
6. The metal heat sink of the protection board is anodized and insulated, and the oxide layer will still be conductive after being destroyed. Avoid contact between the heat sink and the battery core and the nickel strip.
7. If you believe you are experiencing any abnormal operation, discontinue use until verified ok by Daly.
8. Do not use the two Daly BMS units in series.
9. Two or more units can be used in parallel if each unit is capable of sustaining the maximum load current.
10. Every product is tested by Daly engineers before shipping.